

Arbeitsbereich GSD-TR

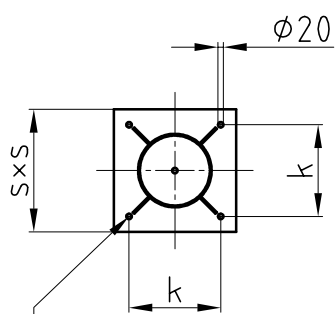

Ankerschraube M16 Qual. St.52
320 mm einbetoniert

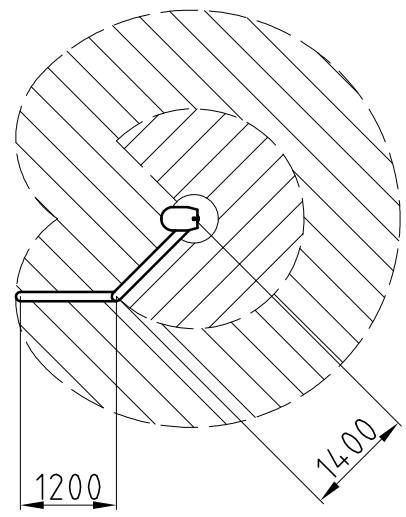

Säulendrehkran		P	a	c	g	h	i	k	s
SD-HR 125/2000	HANDY 125	125 kg	220	2000	3300	600	900	250	300
SD-HR 125/3000	HANDY 125	125 kg	220	3000	3300	600	1000	250	300
SDR 01112	HANDY 125 spez.	125 kg	265	2000	3800	600	900	300	400
SDR 02113	HANDY 125 spez.	125 kg	265	3000	3800	600	1000	300	400
GSD-TR 125	HANDY 125	125 kg	220	2600	3300	600	900	250	300
GSD-TR 250	HANDY 250	250 kg	265	2600	3400	600	1000	300	350

Stückzahl Nombre de pièces				Bezeichnung / Dimension Spécification / Dimension				Werkstoff Matière		Pos. Rep.	Artikel-Nr. No. d'article				
VI	III	II	I	Bemerkungen: Observations:				Klasse: B		Ersetzt durch Remplacé par					
				Status: Norm freigeben				9311_954		Ersatz für Remplace					
				Fundament-Plan Handy				Massstab Echelle		Gezeichnet Dessiné		09.04.00		P.ENGEL	
								1:1		Bearbeitet Modifié par		20.11.06		D.BUCHER	
								%		Geprüft Contrôlé		18.09.02		ESTERMANN	
										Freigabe Norm Autorisé norm		18.09.02		P.ENGEL	