

4

3

2

1

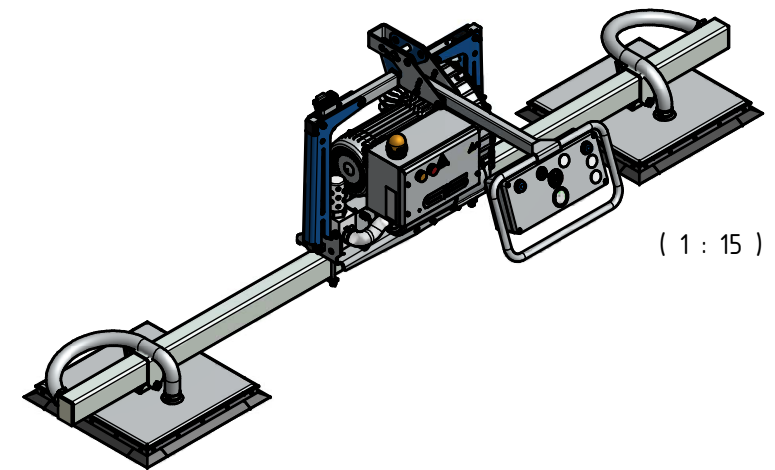
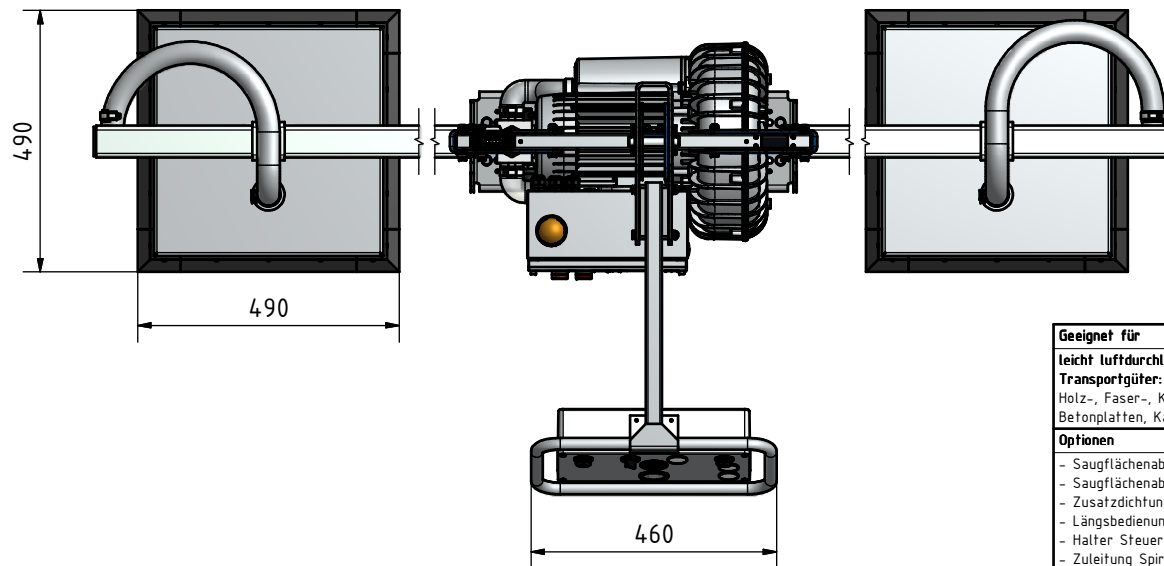
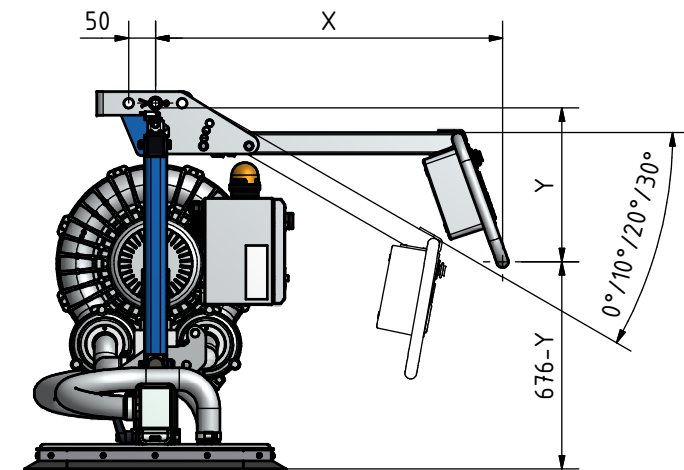
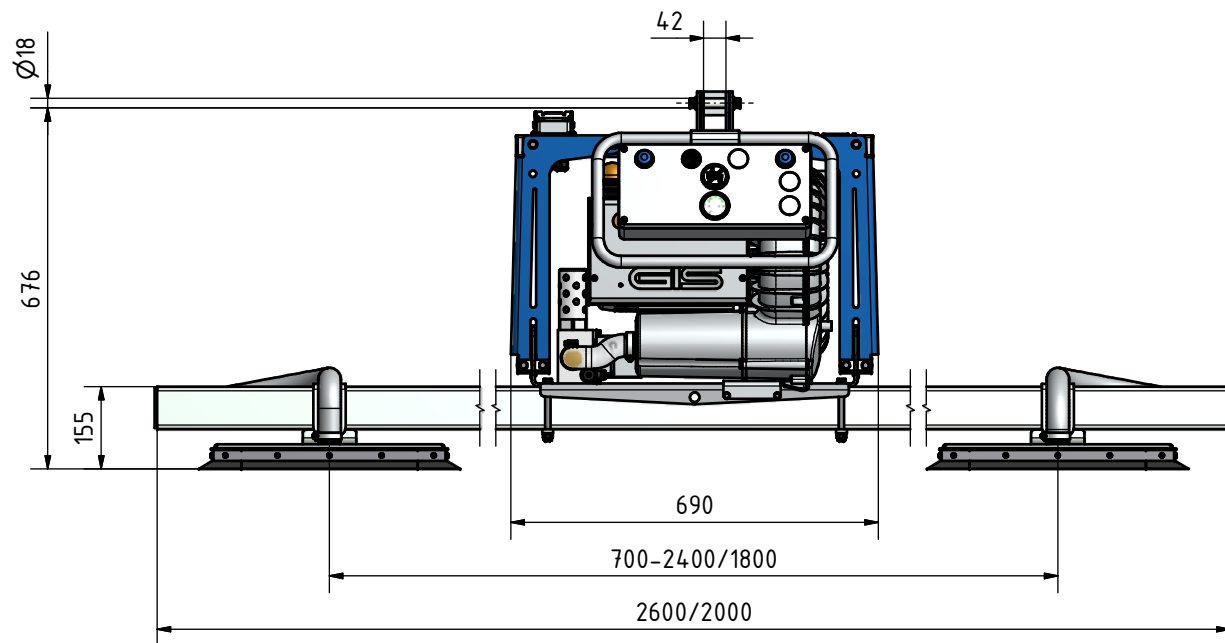

(1 : 15)

Geeignet für leicht luftdurchlässige und luftdichte Transportgüter: Holz-, Faser-, Kunststoff-, und Betonplatten, Karton	Suited for slightly air permeable and airtight goods: wooden boards, fibreboards, plastic boards, concrete slabs, cardboard	Convient aux marchandises légèrement perméables à l'air: panneaux de bois, de fibres et de plastique, plaques de béton, cartons
Optionen - Saugflächenabschaltung - Saugflächenabstützung - Zusatzdichtung Spörri - Längsbedienung - Halter Steuerschalter - Zuleitung Spiralkabel - Zuleitung Kabelrolle	Options - Shutdown mechanism for vacuum surfaces - Suction-surface support - Suction surface with extra gasket - Stirup operating arm longitudinal - Control switch holder - Power supply with spiral cable - Power supply with cable reel	Options - Robinet à rotule pour surfaces - Blocage des tampons de levage - Surfaces d'aspiration avec additif joint - Bras de manoeuvre longitudinal - Support pour l'interrupteur de commande - Alimentation avec câble en spirale - Alimentation avec enrouleur câble

Tragfähigkeit Load capacity Capacité de charge	Leistung Motor power Puissance	3 x 400V 50Hz	Schalldruckpegel Sound pressure level Niveau de pression acoustique	Eigengewicht Dead weight Poids propre	Max. Abmessung Transportgut Max. dimensions of lifting load Dimension max. de la marchandise transportée	Min. Abmessung Transportgut Min. dimensions of lifting load Dimension min. de la marchandise transportée	Bedienung 650mm Operating arm 650mm Commande 650mm				Bedienung 1050mm Operating arm 1050mm Commande 1050mm				
							0°	10°	20°	30°	0°	10°	20°	30°	
[kg]	[kW]	[A]	[dBA]	[kg]	[mm]	[mm]	650	605	547	478	1050	999	923	824	X
max. 500	2.2	6	75	120	3000 x 5000 3000 x 4000	500 x 1200 x 8	288	367	437	496	288	436	574	696	Y

Freigegeben			Klasse A	Ersetzt durch	Ersatz für
Rev.	Datum	User			
A	06.07.2017	J.SUPPIGER	GN 500kg	Massstab	1 /
Gezeichnet	11.12.2013	A.HADORN			
 swiss lifting solutions			9351.9302.5	Revision A	

4

3

2

1