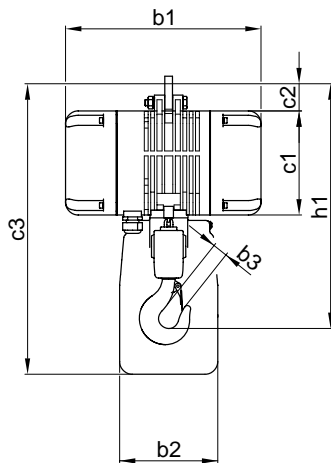
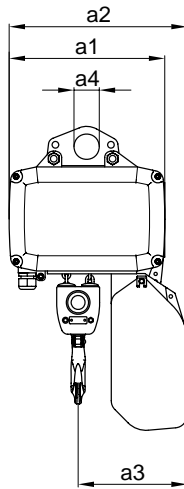

Elektrokettenzüge GCH

- Schützensteuerung 42 Volt mit Not-Aus
- Getriebeendschalter für höchste und tiefste Hakenstellung
- Verschleißfeste Rutschkupplung als Überlastsicherung; Belag asbestfrei
- Gehärtetes Getriebe mit Dauerschmierung
- Verschleißfeste Bremse
- Spezialekette nach DIN 5684, galvanisch verzinkt, oberflächengehärtet
- Lasthaken nach DIN 15401
- Schutzart: IP 55 nach DIN 40050
- Isolierstoffklasse: F

Leistungsdaten

Triebwerkgruppe ISO (FEM)	M3 (1Bm) 150 S/h 25% ED	M4 (1Am) 180 S/h 30% ED	M5 (2m) 240 S/h 40% ED	M6 (3m) 300 S/h 50% ED	M7 (4m) 360 S/h 60% ED	Hubgeschwindigkeit [m/min]	Leistung (M3) [kW]	3 x 400V 50Hz (M3) [A]	Strangzahl	Eigen-gewicht 3 m Hub [kg]
Baureihe	Tragfähigkeit [kg]									
GCH 250/1 N	250	200	160	125	100	8	0.36	1.3	1	19
GCH 250/1 NF	250	200	160	125	100	8/2	0.36/0.09	2.7/3.0	1	22
GCH 250/1 SF	160	125	100	100	100	12.5/3	0.36/0.09	2.7/3.0	1	22
GCH 250/1 HF	100	100	100	100	100	20/5	0.36/0.09	2.7/3.0	1	22
GCH 250/2 N	500	400	320	250	200	4	0.36	1.3	2	22.5
GCH 250/2 NF	500	400	320	250	200	4/1	0.36/0.09	2.7/3.0	2	23
GCH 250/2 SF	320	250	200	160	125	6.25/1.5	0.36/0.09	2.7/3.0	2	23
GCH 500/1 N	500	400	320	250	200	8	0.72	2.1	1	20
GCH 500/1 NF	500	400	320	250	200	8/2	0.72/0.18	2.9/3.0	1	22.5
GCH 500/1 SF	320	250	200	160	125	12.5/3	0.72/0.18	2.9/3.0	1	22.5
GCH 500/1 HF	200	160	125	100	100	20/5	0.72/0.18	2.9/3.0	1	22.5
GCH 500/2 N	1'000	800	630	500	400	4	0.72	2.1	2	24.5
GCH 500/2 NF	1'000	800	630	500	400	4/1	0.72/0.18	2.9/3.0	2	25
GCH 500/2 SF	630	500	400	320	250	6.25/1.5	0.72/0.18	2.9/3.0	2	25
GCH 1000/1 N	1'000	800	630	500	400	8	1.45	3.7	1	45
GCH 1000/1 NF	1'000	800	630	500	400	8/2	1.45/0.36	4.0/2.8	1	46
GCH 1000/1 SF	500	400	320	250	200	16/4	1.45/0.36	5.8/2.6	1	48
GCH 1000/2 N	2'000	1'600	1'250	1'000	800	4	1.45	3.7	2	50
GCH 1000/2 NF	2'000	1'600	1'250	1'000	800	4/1	1.45/0.36	4.0/2.8	2	51
GCH 1000/2 SF	1'000	800	630	500	400	8/2	1.45/0.36	5.8/2.6	2	53
GCH 1600/1 N	1'600	1'250	1'000	800	630	8	2.44	6.0	1	63
GCH 1600/1 NF	1'600	1'250	1'000	800	630	8/2	2.44/0.61	6.6/4.2	1	65
GCH 1600/1 SF	1'000	800	630	500	400	12.5/3	2.39/0.58	6.6/4.2	1	65
GCH 1600/2 N	3'200	2'500	2'000	1'600	1'250	4	2.44	6.0	2	73
GCH 1600/2 NF	3'200	2'500	2'000	1'600	1'250	4/1	2.44/0.61	6.6/4.2	2	75
GCH 1600/2 SF	2'000	1'600	1'250	1'000	800	6.25/1.5	2.39/0.58	6.6/4.2	2	75
GCH 2000/1 N	2'000	1'600	1'250	1'000	800	8	3.05	7.3	1	65
GCH 2000/1 NF	2'000	1'600	1'250	1'000	800	8/2	3.05/0.77	8.0/4.5	1	67
GCH 2000/1 SF	1'250	1'000	800	630	500	12.5/3	2.98/0.72	8.0/4.5	1	67
GCH 2000/2 N	4'000	3'200	2'500	2'000	1'600	4	3.05	7.3	2	76
GCH 2000/2 NF	4'000	3'200	2'500	2'000	1'600	4/1	3.05/0.77	8.0/4.5	2	78
GCH 2000/2 SF	2'500	2'000	1'600	1'250	1'000	6.25/1.5	2.98/0.72	8.0/4.5	2	78
GCH 2500/1 N	2'500	2'000	1'600	1'250	1'000	6.4	3.05	7.7	1	65
GCH 2500/1 NF	2'500	2'000	1'600	1'250	1'000	6.4/1.6	3.05/0.77	8.2/4.4	1	67
GCH 2500/1 SF	1'600	1'250	1'000	800	630	10/2.5	3.05/0.77	8.2/4.4	1	67
GCH 2500/2 N	5'000	4'000	3'200	2'500	2'000	3.2	3.05	7.7	2	76
GCH 2500/2 NF	5'000	4'000	3'200	2'500	2'000	3.2/0.8	3.05/0.77	8.2/4.4	2	78
GCH 2500/2 SF	3'200	2'500	2'000	1'600	1'250	5/1.25	3.05/0.77	8.2/4.4	2	78

Abmessungen

Baureihe	a1 [mm]	a2 [mm]	a3 [mm]	a4 [mm]	b1 [mm]	b2 [mm]	b3 [mm]	c1 [mm]	c2 [mm]	c3 [mm]	h1 [mm]
GCH 250/1	246	281	146	40	309	155	22	164	53	398	369
GCH 250/2	246	281	164	40	309	155	22	164	53	398	408
GCH 500/1	246	281	146	40	309	155	22	164	53	398	377
GCH 500/2	246	281	169	40	309	155	22	164	53	398	417
GCH 1000/1	321	367	190	52	367	180	32	214	69	565	482
GCH 1000/2	321	367	224	52	367	180	32	214	69	565	556
GCH 1600/1	345	424	220	75	389	180	37	230	135	646	608
GCH 1600/2	345	424	263	75	389	180	37	230	135	646	690
GCH 2000/1	345	424	220	75	389	180	37	230	135	646	608
GCH 2000/2	345	424	263	75	389	180	37	230	135	646	690
GCH 2500/1	345	424	220	75	389	180	37	230	135	646	608
GCH 2500/2	345	424	263	75	389	180	37	230	135	646	690

Standard : Hub 3 m / Steuerkabel 1.8 m
 GCH 250/500 und GCH 1000: Aufhängung mit Ringöse
 GCH 1600/2000/2500: ohne Aufhängeteile

Optionen : Verlängerte Lastkette / Steuerkabel (bis 120 m Hub)
 GCH 250/500 und GCH 1000: Aufhängung mit Haken
 GCH 1600/2000/2500: Aufhängung mit Ringöse oder Haken; Aufhängeteil für Fahrwerke

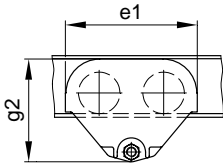
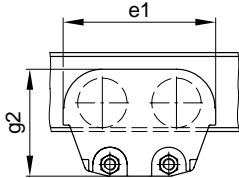
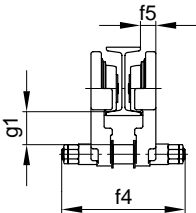
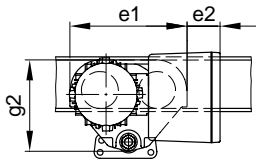
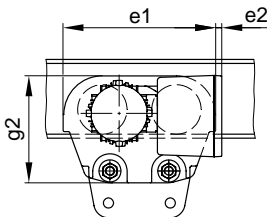
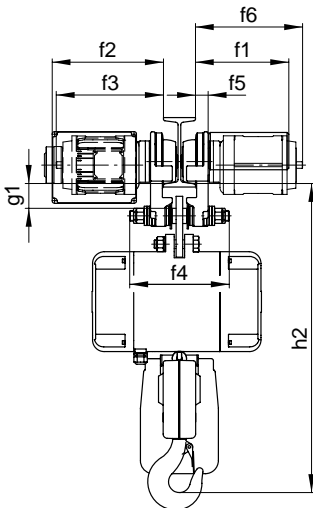
Handfahrwerke EHF und Motorfahrwerke EMFE
EHF 50/150

EHF 300/500

EHF 50/150/300/500

EMFE 50/150

EMFE 300/500

EMFE 50/150/300/500

Leistungsdaten

Triebwerkgruppe ISO (FEM)	M3 (1Bm) 150 S/h 25% ED	M4 (1Am) 180 S/h 30% ED	M5 (2m) 240 S/h 40% ED	M6 (3m) 300 S/h 50% ED	M7 (4m) 360 S/h 60% ED	Fahrge- schwin- digkeit	Leistung (M3)	3 x 400V 50Hz (M3)	Eigen- gewicht
Baureihe	Tragfähigkeit [kg]					[m/min]	[kW]	[A]	[kg]
EHF 50	1'000	800	630	630	500	-	-	-	7.5
EMFE 50/N	1'000	800	630	630	500	12	0.25	0.8	27
EMFE 50/NF	1'000	800	630	630	500	12/4	0.15/0.045	0.65/0.75	27
EMFE 50/SF	800	800	630	630	500	20/6	0.15/0.045	0.65/0.75	27
EHF 150	2'000	2'000	1'600	1'600	1'250	-	-	-	13.5
EMFE 150/N	2'000	2'000	1'600	1'600	1'250	12	0.25	0.8	31
EMFE 150/NF	2'000	2'000	1'600	1'600	1'250	12/4	0.15/0.045	0.65/0.75	31
EMFE 150/SF	1'600	1'600	1'600	1'600	1'250	20/6	0.15/0.045	0.65/0.75	31
EHF 300	4'000	4'000	3'200	2'500	2'500	-	-	-	27.5
EMFE 300/N	4'000	4'000	3'200	2'500	2'500	12	0.25	0.8	50
EMFE 300/NF	4'000	4'000	3'200	2'500	2'500	12/4	0.15/0.045	0.65/0.75	50
EMFE 300/SF	3'200	3'200	3'200	2'500	2'500	20/6	0.15/0.045	0.65/0.75	50
EHF 500	5'000	4'000	3'200	3'200	2'500	-	-	-	27.5
EMFE 500/N	5'000	4'000	3'200	3'200	2'500	12	2x0.25	2x0.8	57
EMFE 500/NF	5'000	4'000	3'200	3'200	2'500	12/4	2x0.15/0.045	2x0.65/0.75	57
EMFE 500/SF	4'000	4'000	3'200	3'200	2'500	20/6	2x0.15/0.045	2x0.65/0.75	57

Abmessungen

Baureihe	e1 [mm]	e2 [mm]	f1 [mm]	f2 [mm]	f3 [mm]	f4 [mm]	f5 [mm]	f6 [mm]
EHF 50	215	-	-	-	-	183	23	-
EMFE 50	215	62	209	250	241	183	23	-
EHF 150	250	-	-	-	-	230	27	-
EMFE 150	250	43	211	253	242	230	27	-
EHF 300	311	-	-	-	-	290	31	-
EMFE 300	311	12	217	259	249	290	31	-
EHF 500	311	-	-	-	-	290	31	-
EMFE 500	311	12	-	259	249	290	31	249

Baureihe	g1 [mm]	g2 [mm]	h2 [mm]				Flanscbreite [mm]
			GCH 250/1	GCH 250/2	GCH 500/1	GCH 500/2	
EHF 50	49	167	418	457	426	466	50 - 99
EMFE 50	49	167	418	457	426	466	50 - 99
			GCH 1000/1	GCH 1000/2			
EHF 150	60	203	542	616			76 - 139
EMFE 150	60	203	542	616			76 - 139
			GCH 1600/1	GCH 1600/2	GCH 2000/1	GCH 2000/2	
EHF 300	55	218	637	719	637	719	120 - 179
EMFE 300	55	218	637	719	637	719	120 - 179
			GCH 2500/1	GCH 2500/2			
EHF 500	55	218	637	719			120-179
EMFE 500	55	218	637	719			120-179

Optionen : andere Flanscbreiten
Motorfahrwerk mit Bremse

Normspannungen : 3Ph 230V, 50Hz; 3Ph 400V, 50Hz

Spezialspannungen : auf Anfrage

Zuordnung der Fahrwerke..... : GCH 250/500..... : EHF/EMFE 50
GCH 1000..... : EHF/EMFE 150

GCH 1600/2000 ... : EHF/EMFE 300
GCH 2500..... : EHF/EMFE 500

GIS AG

Hebe- und Fördertechnik
Luzernerstrasse 50
CH-6247 Schötz
Tel. +41 (0)41 984 11 33
Fax +41 (0)41 984 11 44

tel@gis-ag.ch
www.gis-ag.ch

GIS GmbH

Hebe- und Fördertechnik
Feldbergstrasse 17
DE-79689 Maulburg
Tel. +49 (0)7622 677 30
Fax +49 (0)7622 677 319

mail@gis-gmbh.de
www.gis-gmbh.de