

**Annex to the certificate concerning the examination of conformity
No. KP 466 dated 2015-12-18**

1. Intended use

1.1 General

The intended use of chain hoists of types GCH250/..., GCH500/..., GCH1000/..., GCH1600/..., GCH2000/... and GCH2500/... is the lifting and lowering of loads.

1.2 Object of examination

The electric chain hoists are driven by induction motors. For models with two speeds these motors have a pole switch. The braking system consists of a directed current driven magnetic break. This provides the braking momentum via compression springs in the case of loss of energy supply. A slip clutch protects the chain hoist from overloading.

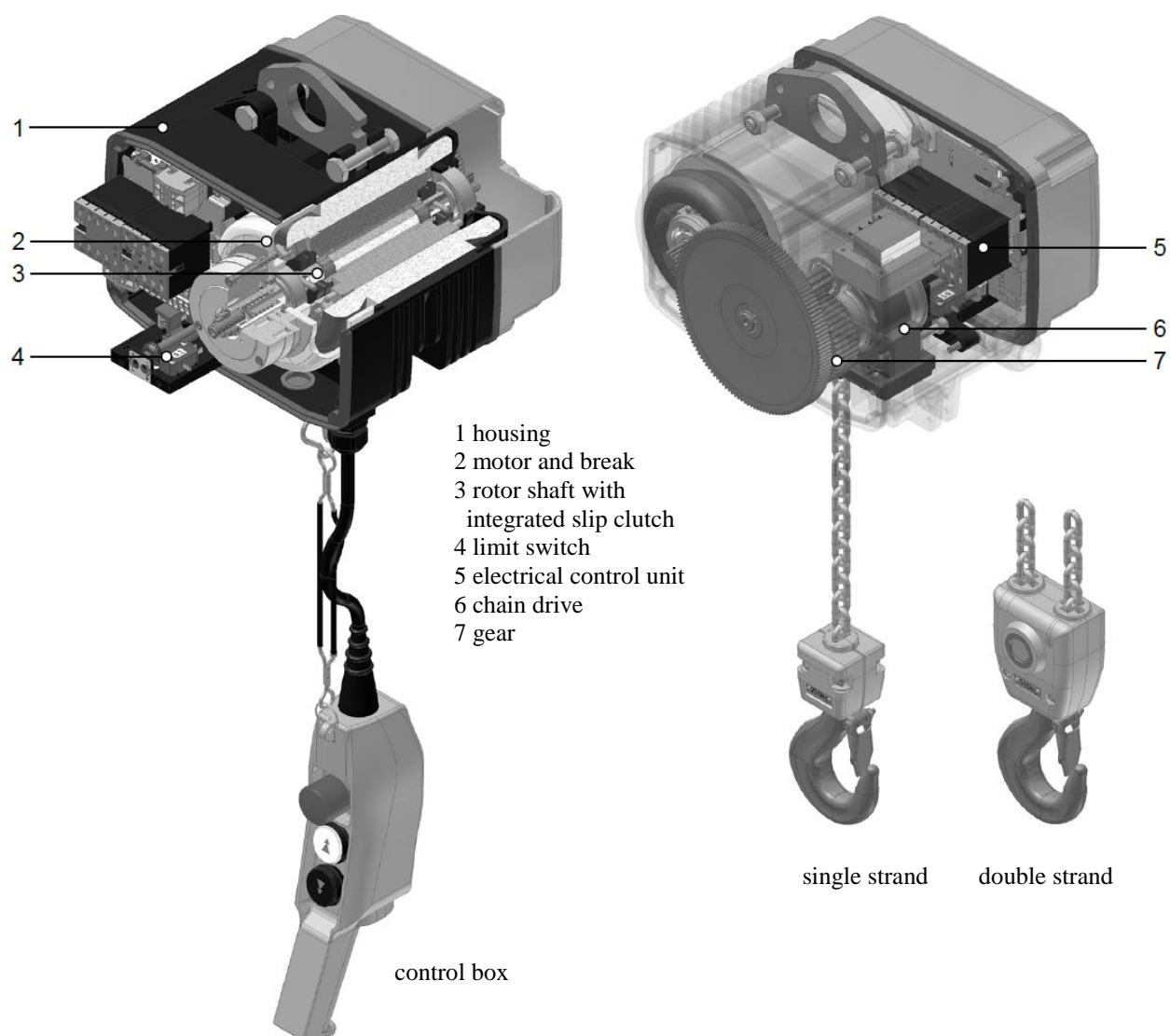
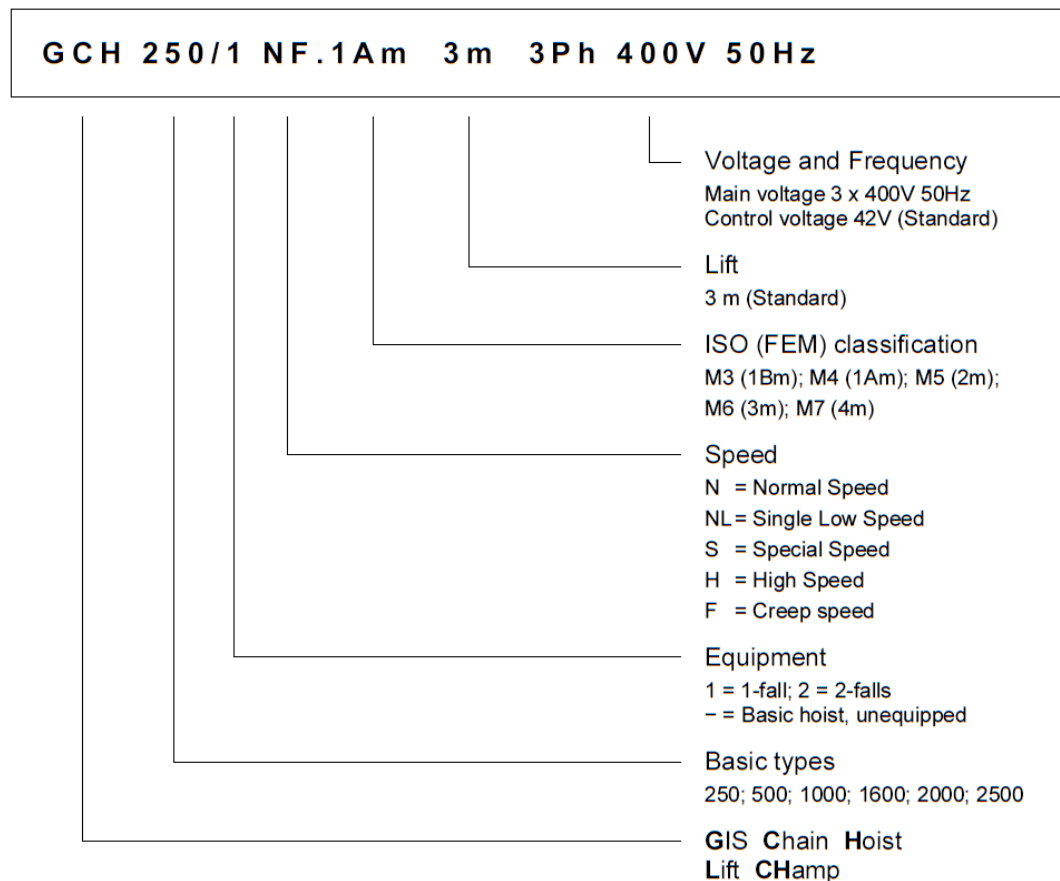

Fig. 1: chain hoist GCH250

1.3 Technical data

The chain hoists of the GCH series have rated loads between 250 and 2500 kg according to classification M3 of ISO 4301-1. The sizes and with this the rated loads can be read from the name of the chain hoist as displayed in Fig. 2.

Marking of GIS electric chain hoists - GCH-Series



GCH electric chain hoists in special executions

Type	Description
GCHK	Low headroom hoist
GCHS	Synchron electric chain hoist
GCHHK	Handy chain hoist
GCHHTD	Handy double telescopic hoist
GCHFU	Electric chain hoist with Frequency control
GCHO	Electric chain hoist without control, with limit switch for control voltage
GCHOD	Electric chain hoist without control, without limit switch
GCHR	Electric chain hoist in stainless steel execution
GCHRO	Electric chain hoist with roller chain wheel
LCH	Electric chain hoist for entertainment industry (D8 / D8 Plus / C1)

Fig. 2: naming scheme for chain hoists



In case of use of a double strand the rated load increases to twice the value. Some types have reduced rated loads. Another factor influencing the rated load is the drive classification. Further details can be seen from tables on pages 19 and 20 of the user's manual.

Drive rating ISO (FEM)	M3 (1Bm) 150 S/h 25% ED	M4 (1Am) 180 S/h 30% ED	M5 (2m) 240 S/h 40% ED	M6 (3m) 300 S/h 50% ED	M7 (4m) 360 S/h 60% ED	Lifting speed	power (M3)	3 x 400V 50Hz (M3)	1 x 230V 50Hz (M3)	Number of strands	Weight with 3 m hoist- ing capaci- ty	fuse
type	Rated load [kg]					[m/min]	[kW]	[A]	[A]		[kg]	[A]
GCH 250/1N	250	200	160	125	100	8	0.36	1.3	-	1	19	10
GCH 250/1NF	250	200	160	125	100	8/2	0.36/0.09	2.7/3.0	-	1	22	10
GCH 250/1SF	160	125	100	100	100	12.5/3	0.36/0.09	2.7/3.0	-	1	22	10
GCH 250/1HF	100	100	100	100	100	20/5	0.36/0.09	2.7/3.0	-	1	22	10
GCH 250/1N 1Ph	160	-	-	-	-	8	0.23	-	8.9	1	19	10
GCH 250/2N	500	400	320	250	200	4	0.36	1.3	-	2	22.5	10
GCH 250/2NF	500	400	320	250	200	4/1	0.36/0.09	2.7/3.0	-	2	23	10
GCH 250/2SF	320	250	200	200	200	6.25/1.5	0.36/0.09	2.7/3.0	-	2	23	10
GCH 250/2N 1Ph	320	-	-	-	-	4	0.23	-	8.9	2	22.5	10
GCH 500/1N	500	400	320	250	200	8	0.72	2.1	-	1	20	10
GCH 500/1NF	500	400	320	250	200	8/2	0.72/0.18	2.9/3.0	-	1	22.5	10
GCH 500/1SF	320	250	200	160	125	12.5/3	0.72/0.18	2.9/3.0	-	1	22.5	10
GCH 500/1HF	200	160	125	100	100	20/5	0.72/0.18	2.9/3.0	-	1	22.5	10
GCH 500/1N 1Ph	250	-	-	-	-	8	0.36	-	8.9	1	20	10
GCH 500/2N	1'000	800	630	500	400	4	0.72	2.1	-	2	24.5	10
GCH 500/2NF	1'000	800	630	500	400	4/1	0.72/0.18	2.9/3.0	-	2	25	10
GCH 500/2SF	630	500	400	320	250	6.25/1.5	0.72/0.18	2.9/3.0	-	2	25	10
GCH 500/2N 1Ph	500	-	-	-	-	4	0.36	-	8.9	2	24.5	10
GCH 1000/1N	1'000	800	630	500	400	8	1.45	3.7	-	1	45	10
GCH 1000/1NF	1'000	800	630	500	400	8/2	1.45/0.36	4.0/2.8	-	1	46	10
GCH 1000/1SF	500	400	320	250	200	16/4	1.45/0.36	5.8/2.6	-	1	48	10
GCH 1000/1N 1Ph	500	-	-	-	-	8	0.73	-	6.0	1	46	10
GCH 1000/2N	2'000	1'600	1'250	1'000	800	4	1.45	3.7	-	2	50	10
GCH 1000/2NF	2'000	1'600	1'250	1'000	800	4/1	1.45/0.36	4.0/2.8	-	2	51	10
GCH 1000/2SF	1'000	800	630	500	400	8/2	1.45/0.36	5.8/2.6	-	2	53	10
GCH 1000/2N 1Ph	1'000	-	-	-	-	4	0.73	-	6.0	2	51	10
GCH 1600/1N	1'600	1'250	1'000	800	630	8	2.44	6.0	-	1	63	16
GCH 1600/1NF	1'600	1'250	1'000	800	630	8/2	2.44/0.61	6.6/4.2	-	1	65	16
GCH 1600/1SF	1'000	800	630	500	400	12.5/3	2.39/0.58	6.6/4.2	-	1	65	16
GCH 1600/2N	3'200	2'500	2'000	1'600	1'250	4	2.44	6.0	-	2	73	16
GCH 1600/2NF	3'200	2'500	2'000	1'600	1'250	4/1	2.44/0.61	6.6/4.2	-	2	75	16
GCH 1600/2SF	2'000	1'600	1'250	1'000	800	6.25/1.5	2.39/0.58	6.6/4.2	-	2	75	16
GCH 2000/1N	2'000	1'600	1'250	1'000	800	8	3.05	7.3	-	1	65	16
GCH 2000/1NF	2'000	1'600	1'250	1'000	800	8/2	3.05/0.77	8.0/4.5	-	1	67	16
GCH 2000/1SF	1'250	1'000	800	630	500	12.5/3	2.98/0.72	8.0/4.5	-	1	67	16
GCH 2000/2N	4'000	3'200	2'500	2'000	1'600	4	3.05	7.3	-	2	76	16
GCH 2000/2NF	4'000	3'200	2'500	2'000	1'600	4/1	3.05/0.77	8.0/4.5	-	2	78	16
GCH 2000/2SF	2'500	2'000	1'600	1'250	1'000	6.25/1.5	2.98/0.72	8.0/4.5	-	2	78	16
GCH 2500/1N	2'500	2'000	1'600	1'250	1'000	6.4	3.05	7.7	-	1	65	16
GCH 2500/1NF	2'500	2'000	1'600	1'250	1'000	6.4/1.6	3.05/0.77	8.2/4.4	-	1	67	16
GCH 2500/1SF	1'600	1'250	1'000	800	630	10/2.5	3.05/0.77	8.2/4.4	-	1	67	16
GCH 2500/2N	5'000	4'000	3'200	2'500	2'000	3.2	3.05	7.7	-	2	76	16
GCH 2500/2NF	5'000	4'000	3'200	2'500	2'000	3.2/0.8	3.05/0.77	8.2/4.4	-	2	78	16
GCH 2500/2SF	3'200	2'500	2'000	1'600	1'250	5/1.25	3.05/0.77	8.2/4.4	-	2	78	16

2 Conditions

- 2.1 The chain hoists are only allowed to be operated by personnel trained according to the user's manual.
- 2.2 One copy of the user's manual needs to be kept at the site of use.
- 2.3 Obligations and organizational measures stated in the user's manual have to be obeyed.
- 2.4 A yearly inspection has to be carried out by an expert.
- 2.5 The number of load cycles stated in the user's manual may not be exceeded.



Industrie Service

3 Notes

- 3.1 This product needs to be labeled with information about the producer and the specific type, for being able to check the match with the documentation and serial production.
- 3.2 Prior to expiry of the certificate the notified body needs to be ordered to check the validity of the certificate.
- 3.3 The technical documentation needs to contain at least:
 - 3.4 - a copy of the certificate No KP 466 dated 2015-12-18 with annex
 - 3.5 - a copy of the user's manual GCH 250 – 2500, dated May 2015, pages 1 – 22
- 3.6 The certificate concerning the examination of conformity is only allowed to be used together with this annex.