

TECHNICAL DOCUMENTATION CRANE SYSTEM GISKB III | GISKB IV

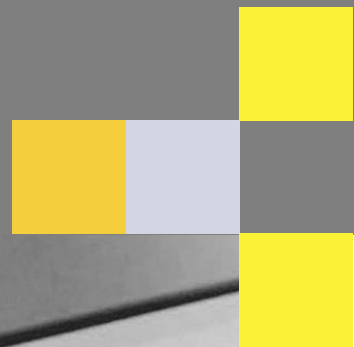

Table of contents

0	General instructions.....	4
0.1	Explanation of signs.....	4
1	Overview.....	5
1.1	Overview suspensions.....	6
2	Directives concerning the suspension points of GISKB small crane systems.....	7
2.1	Distanced monorails.....	7
2.2	Suspended cranes.....	7
2.3	Examples of bracings.....	7
3	Dimensioning suspended crane.....	8
3.1	Crane bridge.....	8
3.2	Crane track / Monorail.....	9
4	Dimensions and approach dimensions.....	10
5	Crane system components.....	11
5.1	Track section.....	11
5.2	Cover.....	12
5.3	Profile junction.....	12
5.4	Trolley.....	13
5.5	Traverse.....	13
5.6	Saddle.....	14
5.7	Suspension part.....	14
5.8	Overview crane bridge suspension.....	15
5.8.1	Single crane bridge pendulating.....	15
5.8.2	Single crane bridge rigid.....	16
5.8.3	Double crane bridge rigid.....	17
5.9	Overview monorail.....	18
5.10	Crane-bridge suspension pendulating.....	19
5.11	Rolling apparatus.....	20
5.12	Reinforcement rolling apparatus.....	20
5.13	Overload protection.....	21
5.14	Profile retainer complete.....	21
5.15	Breaker.....	22
5.16	Suspension pendulating short.....	23
5.17	Suspension pendulating distanced.....	24
5.18	Bracing pendulating distanced.....	25
5.19	Ceiling clip.....	26
5.20	Binding clip complete.....	26
5.21	Support to ceiling clip.....	27
5.22	Lateral suspension.....	27
5.23	GIS adhesive.....	28
5.24	Lifting capacity adhesive.....	28
5.25	Electric tug.....	29
5.26	Connector clamp.....	30
6	Power supply.....	31
6.1	Trailing cable.....	31
6.2	C rail.....	32
6.3	Conductor line.....	33

0 General instructions

This GIS documentation contains information about the lay-out and planning of GISKB suspended crane and monorail up to 2000 kg lifting capacity.

1. The documents allow you a fast and efficient dimensioning of the crane equipments.







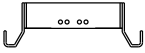

Technical notes:

- The documents for planning are based on the rules of the latest technology.
- Only GIS originally manufactured parts shall be used.
- The customer is responsible for the stability of the ceiling structure.
- Painting: The crane equipment is delivered with a grey primer (RAL 7035).
On request, a finished paint is possible according to your choice or galvanised version.

2. For the components used, the technical specifications, dimensions and the order numbers are given.

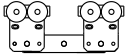
3. In the final pages of this document a questionnaire for the project of GIS light crane systems is added. It should help you to find the necessary data.

0.1 Explanation of signs

	Crane bridge		Saddle
	Profile		Flange width [mm]
	Trolley		Lifting capacity [kg]
	Traverse		Dead weight [kg]
	Rolling apparatus		Electric mains for power supply
		N°	Ordering number

1 Overview

Single bridge suspension crane

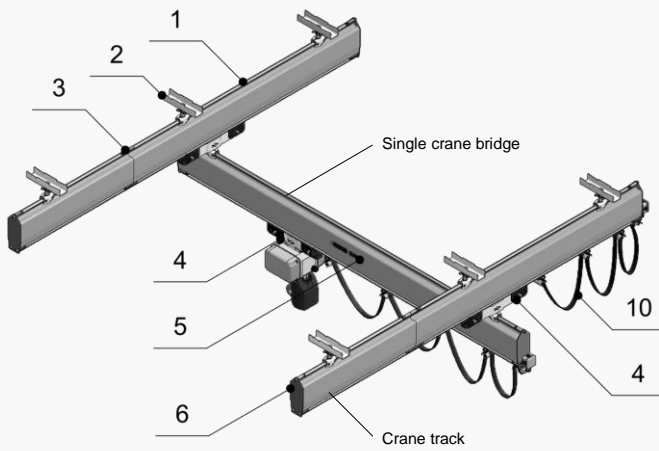

Double bridge suspension crane

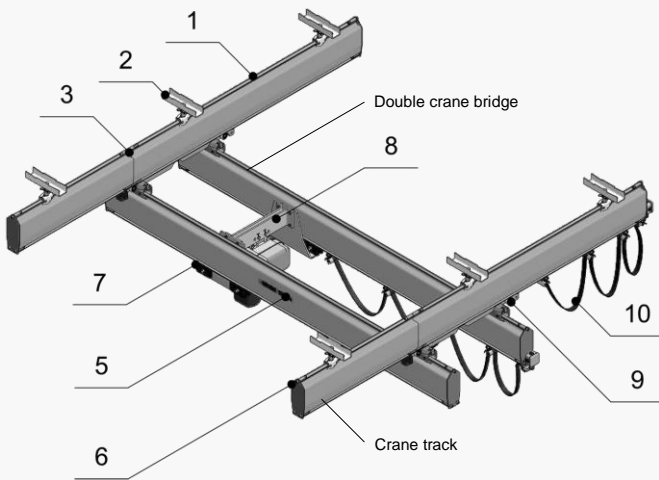

Monorail

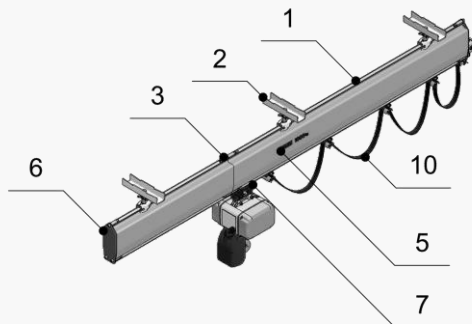

	Page
1 Track section	11
2 Suspension	6
3 Profile junction	12
4 Traverse.....	13
5 Lifting capacity adhesive	28
6 Cover	12
7 Trolley	13
8 Saddle.....	14
9 Rolling apparatus.....	20
10 Power supply	31

1.1 Overview suspensions

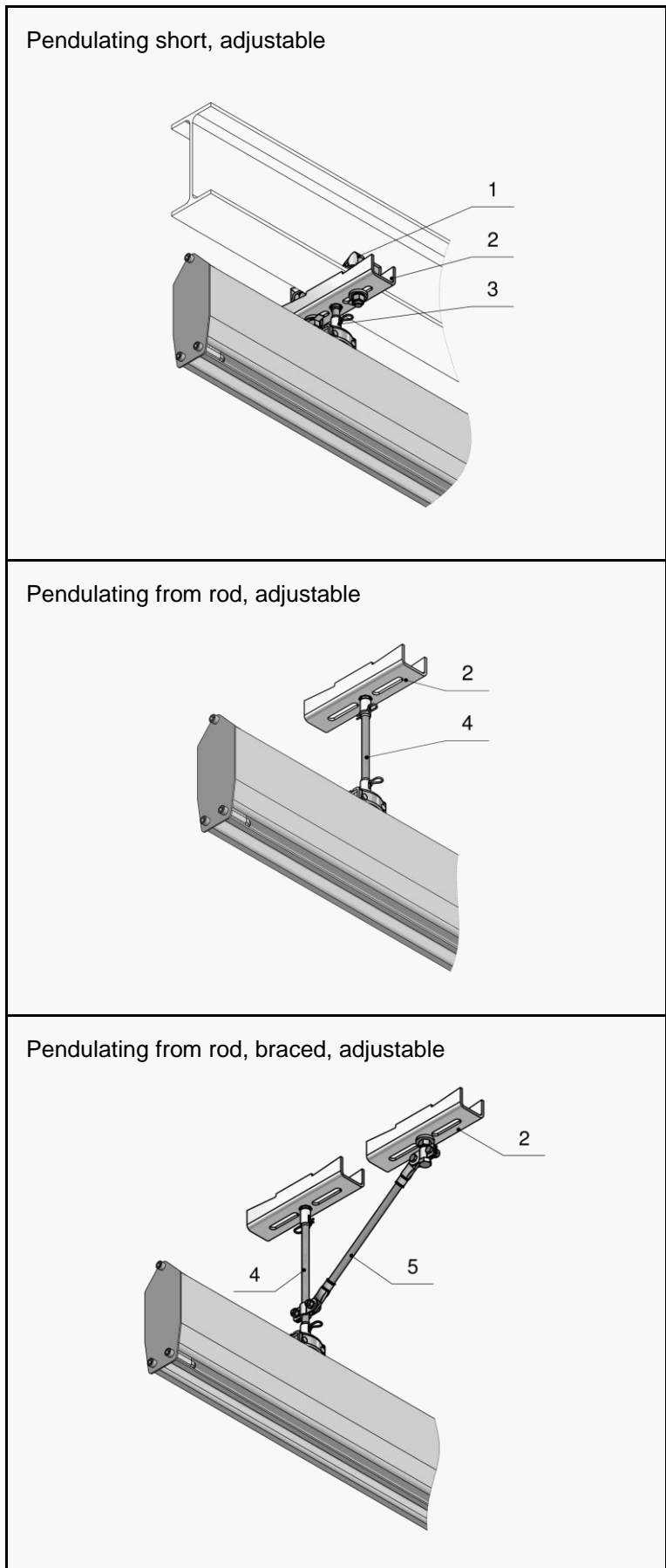

	Page
1 Binding clip complete	26
2 Ceiling clip	26
3 Short suspension	23
4 Distanced suspension	24
5 Bracing	25

2 Directives concerning the suspension points of GISKB small crane systems

The distances between the suspension points depend on the profile size and the strain. This dimensioning is made according to the diagrams or the calculation program. At a load of more than 1600 kg a double suspension is to be provided.

The type of suspension depends on the constructional situation. All suspensions are available pendulating only. Pendulating suspensions are easier to assemble. Inaccurate alignment due to imprecise ceiling structures can be avoided. Care is to be taken that the angle of the suspension does not differ more than 5° from the vertical position.

2.1 Distanced monorails

Monorails suspended from rods must not be braced imperatively provided that no side dragging of hoist exists. Practice, however, shows that a side dragging cannot be excluded, wherefore bracings are to be provided.

For distanced suspensions greater than or equal to $h_4 = 500$ mm (see page 10) transverse and longitudinal bracings are provided. Longitudinal bracings are to be provided for both track ends and lateral bracings for every second suspension.

2.2 Suspended cranes

Combinations for pendulating suspensions:

If the crane track is suspended from the ceiling pendulating, the crane bridge can pendulating or is rigidly connected to the crane track (see page 15 - 16). Double crane bridges must always be rigidly suspended from the crane track (see page 17).

From the ceiling hung distanced crane tracks:

If the suspended cranes are greater than or equal to $h_4 = 500$ mm (see page 10) suspended from the ceiling, both crane tracks have to be braced longitudinally and a crane track lateral. Longitudinal bracings are to be provided for all track ends. Lateral bracings are to be provided for every second suspension only on one crane track.

2.3 Examples of bracings

Monorail (distance greater than or equal to 500 mm)

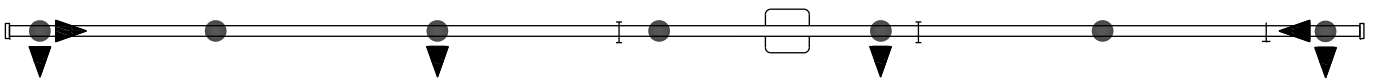

Suspended crane (distance greater than or equal to 500 mm)

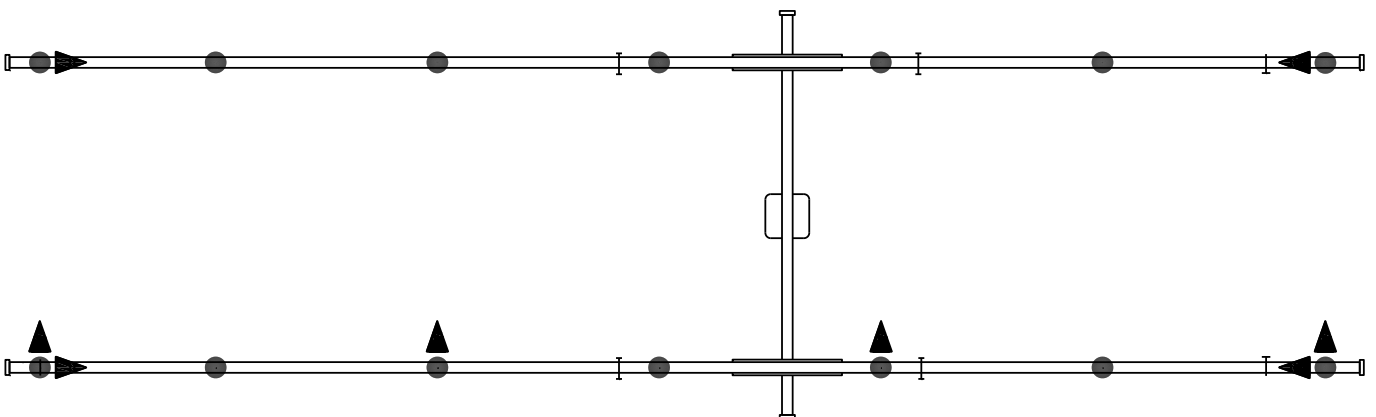

● Symbol suspension

▶ Symbol bracing

3 Dimensioning suspended crane

3.1 Crane bridge

The selection of the profile size depends on the strength (P) and the span (W) of the profile. In tables 3-1 (single crane bridge) and 3-2 (double crane bridge) the adequate profile size can be found.

Load : The strength (P) does include the dead weight of the electric chain hoist and the trolley. The max. admissible load is as follows: GISKB III and GISKB IV = 2400 kg.

Length of span . : The admissible span is shown in the table, depending on the type of profile.
Its maximum is 11800 mm.

The calculations in tables 3-1 and 3-2 are based on a permissible deflection of $W / 400$. The classification of cranes is according to EN 13001: HC4; U2-U3; Q0-Q4; S0-S2 and EN 15018: H2/H3; B3/B4. For other deflection factors there is a calculation program at your disposal.

Admissible load overhang (y): In crane bridges load overhang is permitted only when calculated with the calculation program.

▽ — ▽ without reinforcement

Table 3-1 Single crane bridge span W [m]

Lifting capacity	GISKB III	GISKB IV
	▽ — ▽	▽ — ▽
80 kg	10.2	11.8
100 kg	9.8	11.8
125 kg	9.4	11.8
160 kg	9.0	11.8
200 kg	8.5	11.2
250 kg	8.0	10.7
320 kg	7.3	10.0
400 kg	6.8	9.4
500 kg	6.2	8.7
630 kg	5.6	7.9
800 kg	4.1	5.8
1000 kg	4.6	6.5
1250 kg	3.5	4.9
1600 kg	2.4	3.4
2000 kg	-	-

Table 3-2 Double crane bridge span W [m]

Lifting capacity	GISKB III	GISKB IV
	▽ — ▽	▽ — ▽
80 kg	11.3	11.8
100 kg	11.1	11.8
125 kg	10.8	11.8
160 kg	10.5	11.8
200 kg	10.1	11.8
250 kg	9.7	11.8
320 kg	9.2	11.8
400 kg	8.6	11.4
500 kg	8.1	10.9
630 kg	7.4	10.1
800 kg	6.8	9.4
1000 kg	6.3	8.7
1250 kg	5.7	8.0
1600 kg	5.1	7.2
2000 kg	4.6	6.6

3.2 Crane track / Monorail

The span A is based on the diagrams 3-3 (GISKB III) and 3-4 (GISKB IV). The maximum spans are different in the end field (EF) or middle field (MF). The 1 field solution (1F) has only 2 suspension points and must be calculated separately. The max. admissible load is as follows: GISKB III and GISKB IV = 2400 kg. The load on the crane track or monorail is calculated using the following formulas:

Crane track:

$$P_{KB} = 1.29 \times P_H + 1.1 \times (P_1 + 0.5 \times P_{KT})$$

P_{KB} = load crane track [kg]

P_{HB} = load monorail [kg]

P_H = permissible lifting capacity [kg]

P_1 = dead weight trolley and electric chain hoist [kg]

P_{KT} = dead weight crane bridge [kg]

Monorail:

$$P_{HB} = 1.29 \times P_H + 1.1 \times P_1$$

The length ratio between two adjacent fields must not exceed a value of 1.5 and not fall below the value of 0.5.

Admissible distance of joints (x) : The junction of two track sections shall be at a distance of max. 0.2 x A and a min. of 100 mm from the nearest suspension point.

Admissible load overhang (y) : In case of crane tracks and monorails the load overhang can only be dimensioned with the calculation program.

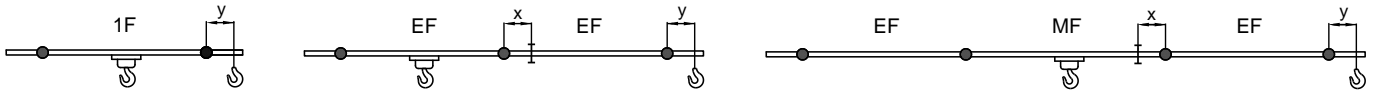

Diagram 3-3 GISKB III

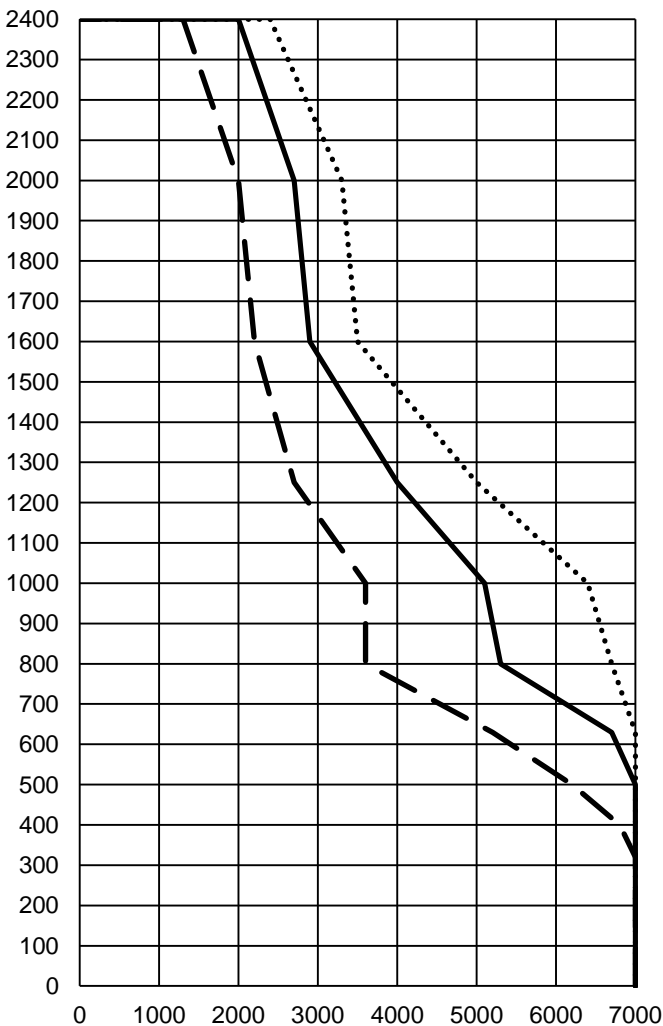
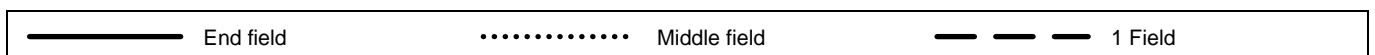
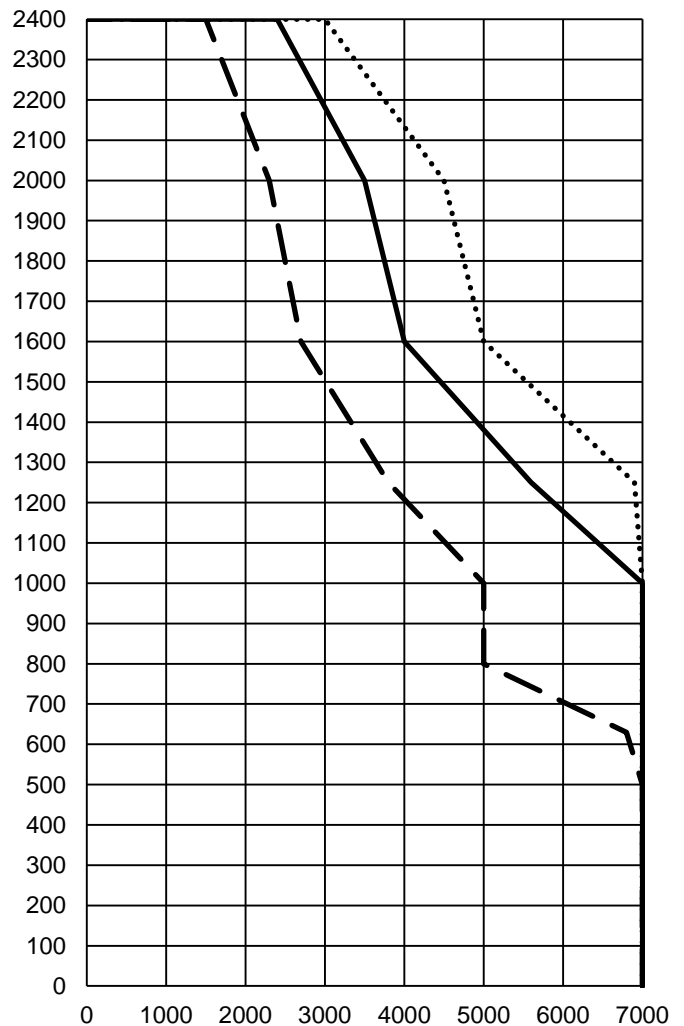
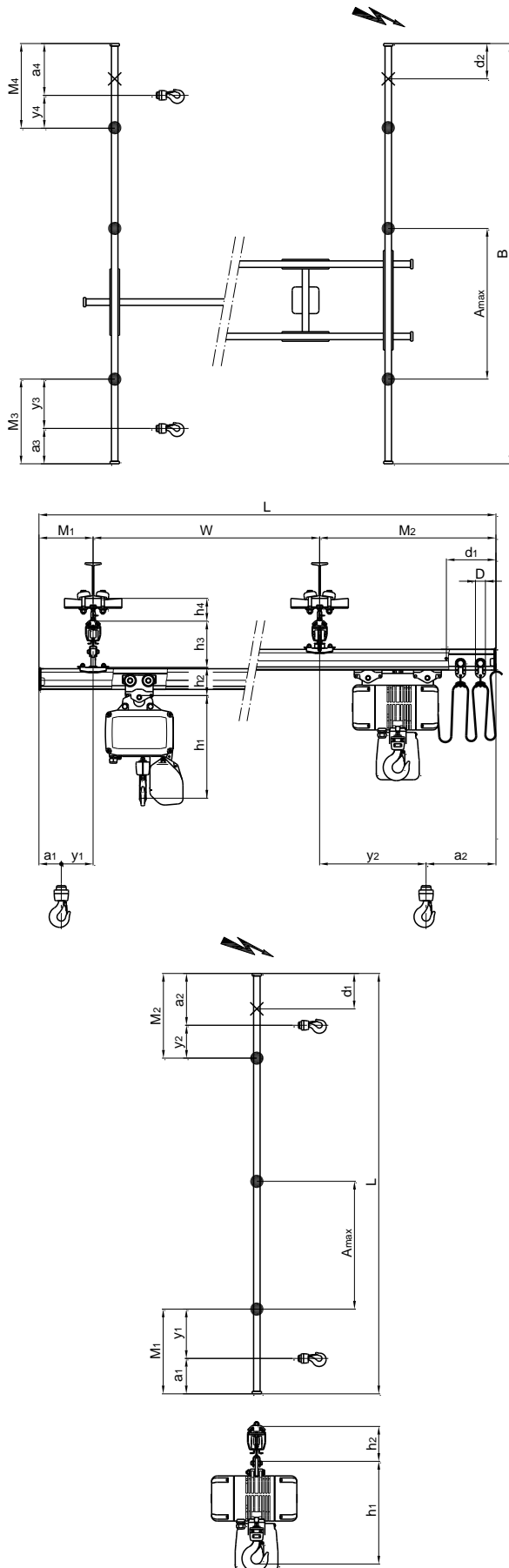

Diagram 3-4 GISKB IV



4 Dimensions and approach dimensions



		GISKB III	GISKB IV
a_1		93 mm	93 mm
a_1 a_3		243 mm	243 mm
a_1		243 mm	243 mm
a_3		500 mm	500 mm
h_1	[mm]	see dimensions of electric chain hoist	
h_2		277 mm	337 mm
h_2		277 mm	337 mm
h_2		128 mm	188 mm
h_3 pendulating		328 mm	388 mm
h_3 rigid		257 mm	317 mm
h_4 pendulating, short		120 ± 7.5 mm	120 ± 7.5 mm
a_2	[mm]	$a_1 + 15 + (x_1 \cdot D)$	
a_4	[mm]	$a_3 + 15 + (x_2 \cdot D)$	
M_1	[mm]	$a_1 + y_1$	
M_2	[mm]	$a_2 + y_2$	
M_3	[mm]	$a_3 + y_3$	
M_4	[mm]	$a_4 + y_4$	
d_1 / d_2	[mm]	$15 + (x_{1(2)} \cdot D)$	
y_{max}	[mm]	see page 8 - 9	
A_{max}	[mm]	see page 9	
W	[mm]	see table 3-1 and table 3-2 page 8	
x_1	[piece]	Cable carriages crane bridge (L:1250) - 1	
x_2	[piece]	Cable carriages crane track (W:1250) - 1	
D	[mm]	Cable carriage = 100	

5 Crane system components

5.1 Track section

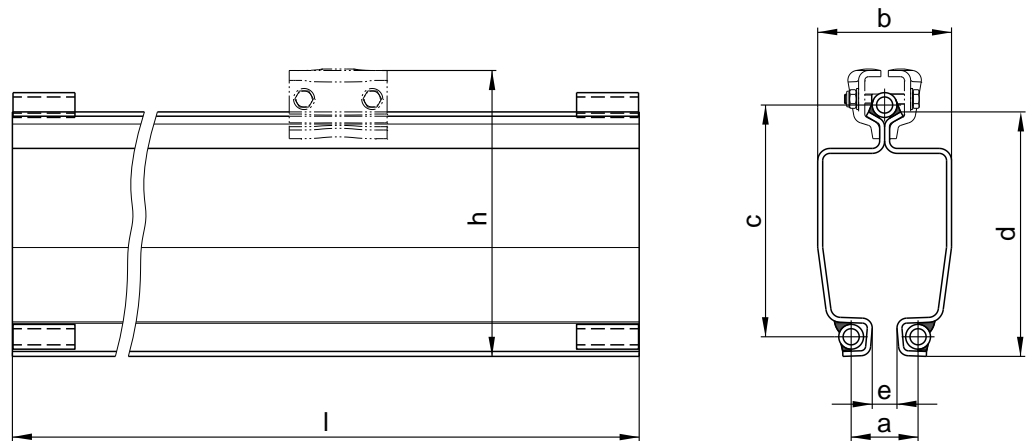

Version.....: GISKB III + IV are cold rolled special track sections with a grey primer. Three tubes are welded to the ends. These tubes are used for the junction of two profiles or for the installation of the track section cover.

Paint.....: RAL 7035 light grey.

Note: The dimensioning is made according to the appropriate documents (see page 8 - 9).

		GISKB III	GISKB IV
	[kg/m]	18.400	22.200
a	[mm]	54	54
b	[mm]	108	108
c	[mm]	187	247
d	[mm]	197	257
e	[mm]	20	20
h	[mm]	231	291
W_x	[mm ³ x 10 ³]	93.18	148.48
I_x	[mm ⁴ x 10 ⁶]	9.169	19.184
l = 1 m		9307.1010.4	9307.1030.4
l = 2 m		9307.1011.4	9307.1031.4
l = 3 m		9307.1012.4	9307.1032.4
l = 4 m		9307.1013.4	9307.1033.4
l = 5 m		9307.1014.4	9307.1034.4
l = 6 m		9307.1015.4	9307.1035.4
l = 7 m		9307.1016.4	9307.1036.4
l = 8 m		9307.1017.4	9307.1037.4
l = 0.001 - 0.999 m		9307.1020.4	9307.1040.4
l = 1.001 - 1.999 m		9307.1021.4	9307.1041.4
l = 2.001 - 2.999 m		9307.1022.4	9307.1042.4
l = 3.001 - 3.999 m		9307.1023.4	9307.1043.4
l = 4.001 - 4.999 m		9307.1024.4	9307.1044.4
l = 5.001 - 5.999 m		9307.1025.4	9307.1045.4
l = 6.001 - 6.999 m		9307.1026.4	9307.1046.4
l = 7.001 - 7.999 m		9307.1027.4	9307.1047.4
l = 8.001 - 12.000 m		9307.1028.4	9307.1048.4

5.2 Cover

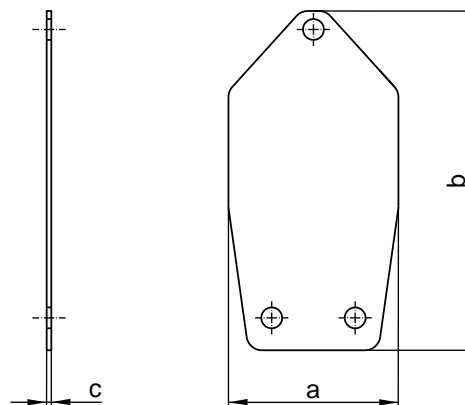

Version: Steel, galvanised.

Use: The cover serves as a track section closure.

Profile	 [kg]	a [mm]	b [mm]	c [mm]		N°
GISKB III	0.500	110	220	3		9307.1057.4
GISKB IV	0.700	110	280	3		9307.1058.4

5.3 Profile junction

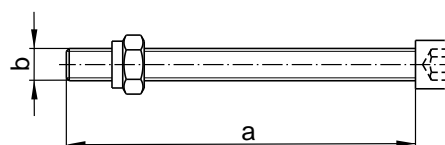

Version: Steel, galvanised.

Use: The junction of two section tracks is made by three high-tensile Allen screws.

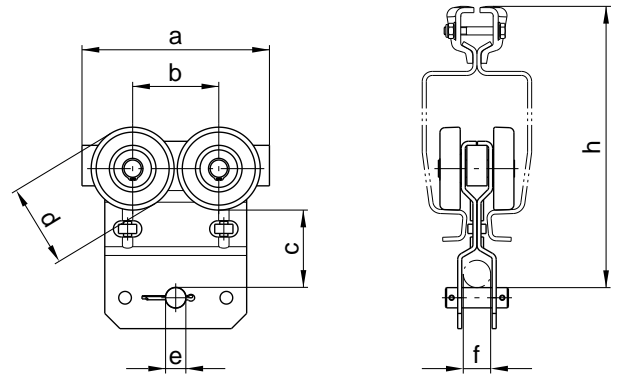

Profile	 [kg]	a [mm]	b		N°
GISKB III + IV	0.600	130	M12		9307.1063.4

5.4 Trolley



Version.....: Steel, galvanised. The trolley is made of steel and equipped with plastic rollers.

Use.....: The trolley is used as a trailer of the electric chain hoist and can also be used as a longitudinal trolley for the crane bridge.

Profile	 [kg]	 [kg]	a [mm]	b [mm]	c [mm]	d [mm]	e [mm]	f [mm]	h [mm]	N°
GISKB III	6.200	800	185	85	77	82	20	27	277	9307.1002.3
GISKB IV	6.200	800	185	85	77	82	20	27	337	9307.1002.3

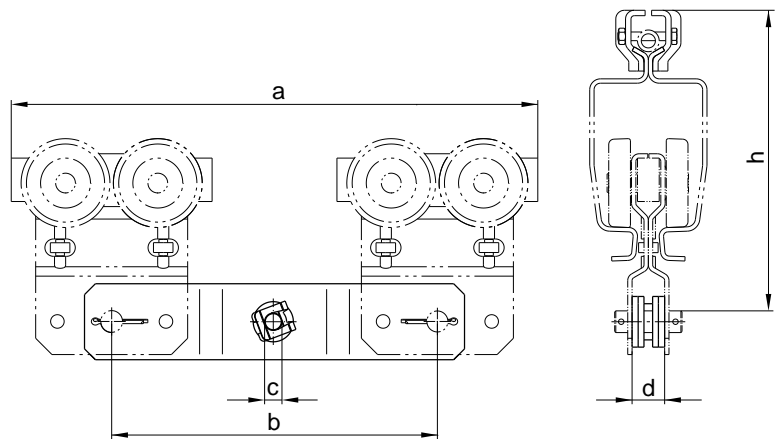

A traverse is coupled with two trolleys so as to favour the load partition. The traverse of the double crane bridge (see page 16) requires 4 trolleys.

5.5 Traverse



Version.....: Steel, galvanised.

Use.....: The traverse allows a coupling of two trolleys.

Profile	 [kg]	 [kg]	a [mm]	b [mm]	c [mm]	d [mm]	h [mm]	N°
GISKB III	3.400	1600	440	300	20	30	341	9307.1006.3
GISKB IV	3.400	1600	440	300	20	30	401	9307.1006.3

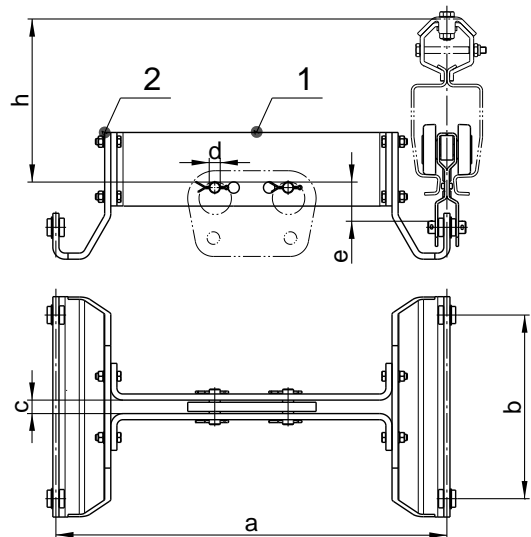

5.6 Saddle





Version: Steel, galvanised.

Use: The saddle allows the junction of four trolleys for the double crane bridge version.

Traverse (Item 1)

Profile	 [kg]	 [kg]	a [mm]	b [mm]	c [mm]	d [mm]	N°
GISKB III + IV	11.000	1600	640	300	22	18	9307.1104.3

Bracket (Item 2)

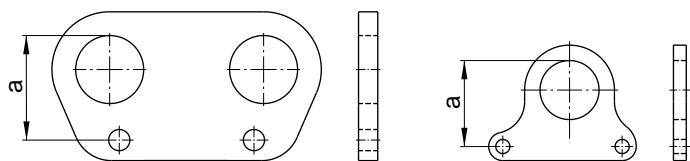

Profile	 [kg]	 [kg]	e [mm]	h [mm]	Designation	N°
GISKB II	5.900	1600	65	116	Bracket saddle	9307.1100.3
GISKB III	8.800	1600	184	123	Bracket saddle above	9307.1101.3
GISKB IV	8.800	1600	184	183	Bracket saddle above	9307.1101.3

5.7 Suspension part



Version: Steel, galvanised.

Use: Suspension of a GCH/GP chain hoist at a traverse or a saddle.

Item	Profile	 [kg]	 [kg]	a [mm]	Designation	N°
1	GISKB III + IV	0.600	1000	67	Eyebolt suspension GCH/GP 250/500	9307.1052.4
	GISKB III + IV	1.100	1600	72	Eyebolt suspension GCH/GP 1000	9307.1049.4
2	GISKB III + IV	0.800	1000	63	Suspension part GCH/GP 250/500	9401.3046.4
	GISKB III + IV	2.000	1600	82	Suspension part GCH/GP 1000	9307.1103.3
	GISKB III + IV	2.800	1600	92	Suspension part GCH 1600/2000/2500	9408.3020.3

5.8 Overview crane bridge suspension

5.8.1 Single crane bridge pendulating

Crane track: GISKB III / GISKB IV, crane bridge: GISKB III / GISKB IV

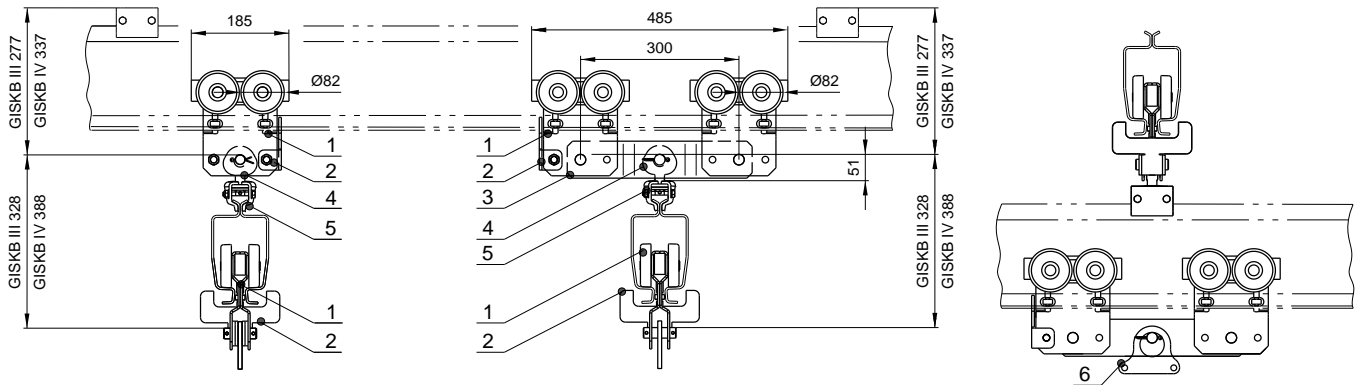

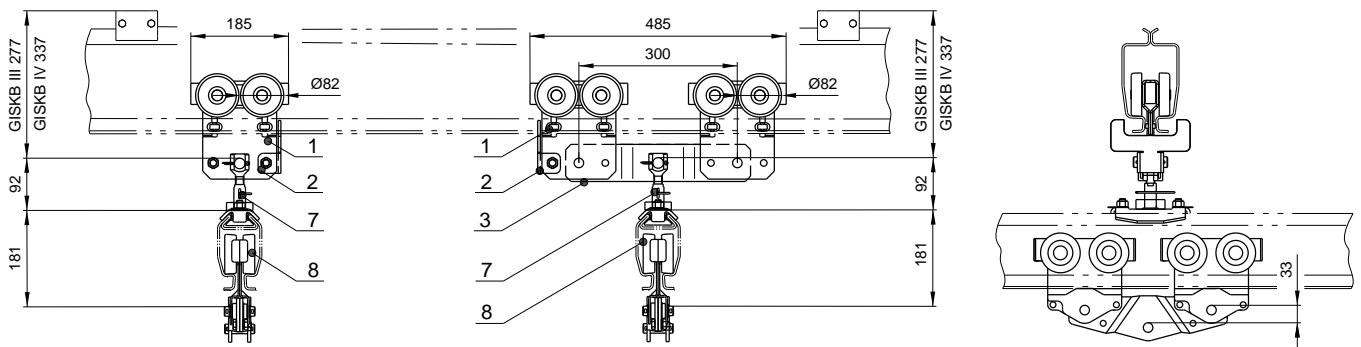

Crane track: GISKB III / GISKB IV, crane bridge: GISKB II

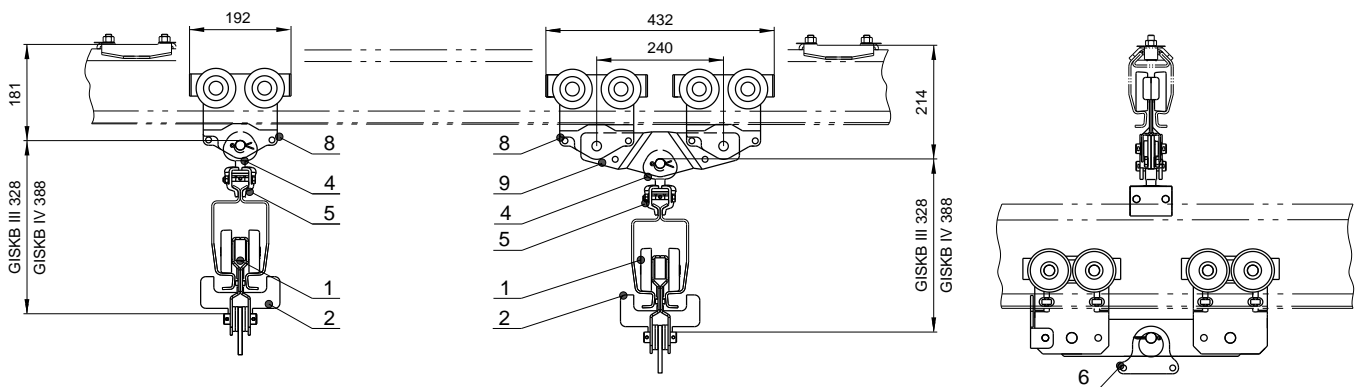

Crane track: GISKB II, crane bridge: GISKB III / GISKB IV



Item	Profile	 [kg]	 [kg]	Designation	N°
1	GISKB III + IV	6.200	800	Trolley	9307.1002.3
2	GISKB III + IV	0.500	1600	Overload protection	9307.1108.4
3	GISKB III + IV	3.400	1600	Traverse	9307.1006.3
4	GISKB III + IV	0.600	1600	Articulated suspension	9307.1003.4
5	GISKB III + IV	0.400	1600	Profile retainer complete	9307.1004.4
6	GISKB III + IV	0.600	1000	Eyebolt suspension GCH 250/500	9307.1052.4
	GISKB III + IV	1.100	1600	Eyebolt suspension GCH 1000	9307.1049.4
7	GISKB III + IV	1.200	1600	Crane bridge suspension	9307.1050.4
8	GISKB II	2.000	800	Trolley	9306.1020.3
9	GISKB I + II	2.000	1600	Traverse	9309.3020.3

5.8.2 Single crane bridge rigid

Crane track: GISKB III / GISKB IV, crane bridge: GISKB III / GISKB IV

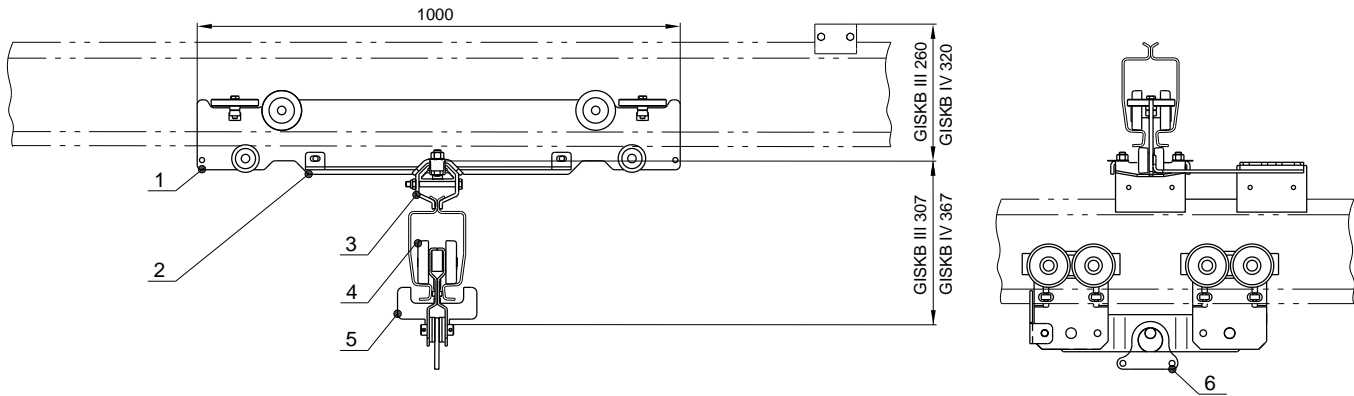

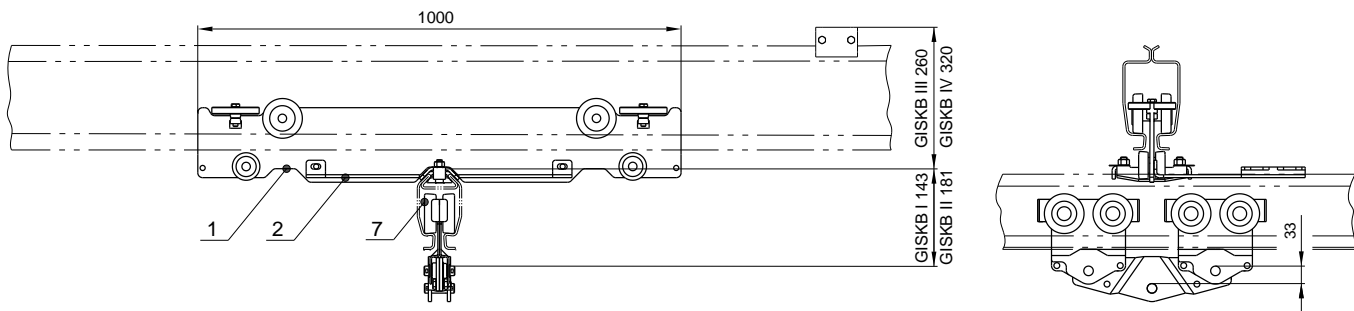

Crane track: GISKB III / GISKB IV, crane bridge: GISKB I / GISKB II

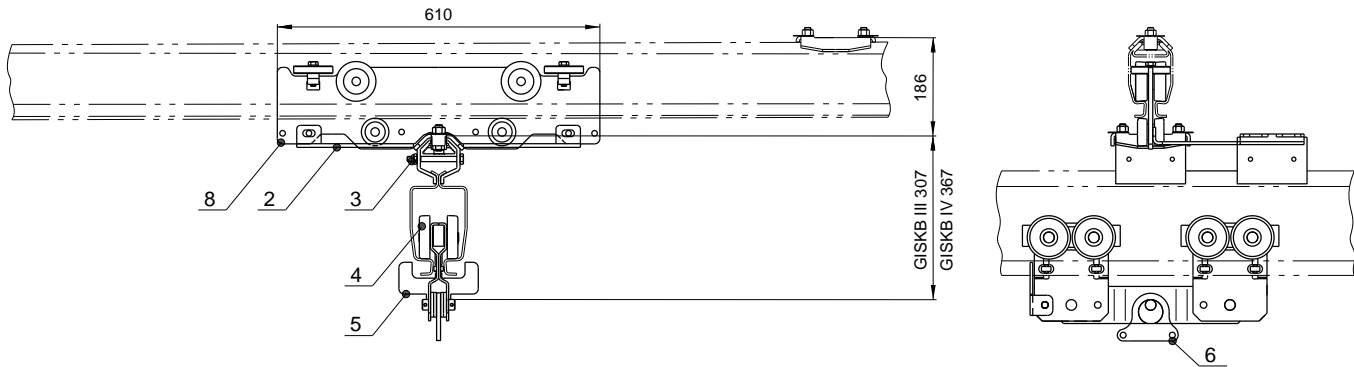

Crane track: GISKB II, crane bridge: GISKB III / GISKB IV



Item	Profile	 [kg]	 [kg]	Designation	N°
1	GISKB III + IV	14.000	1600	Rolling apparatus EQB	9307.1118.3
2	GISKB III + IV	3.000	1600	Reinforcement rolling apparatus	9309.3135.3
3	GISKB III + IV	0.500	1600	Profile retainer complete	9307.1055.3
4	GISKB III + IV	6.200	800	Trolley	9307.1002.3
5	GISKB III + IV	0.500	1600	Overload protection	9307.1108.4
6	GISKB III + IV	0.600	1000	Eyebolt suspension GCH 250/500	9307.1052.4
	GISKB III + IV	1.100	1600	Eyebolt suspension GCH 1000	9307.1049.4
7	GISKB I	1.500	400	Trolley	9305.1020.3
	GISKB II	2.000	800	Trolley	9306.1020.3
8	GISKB II	6.500	1600	Rolling apparatus EQB	9306.1022.3

5.8.3 Double crane bridge rigid

Crane track: GISKB III / GISKB IV, crane bridge: GISKB III / GISKB IV

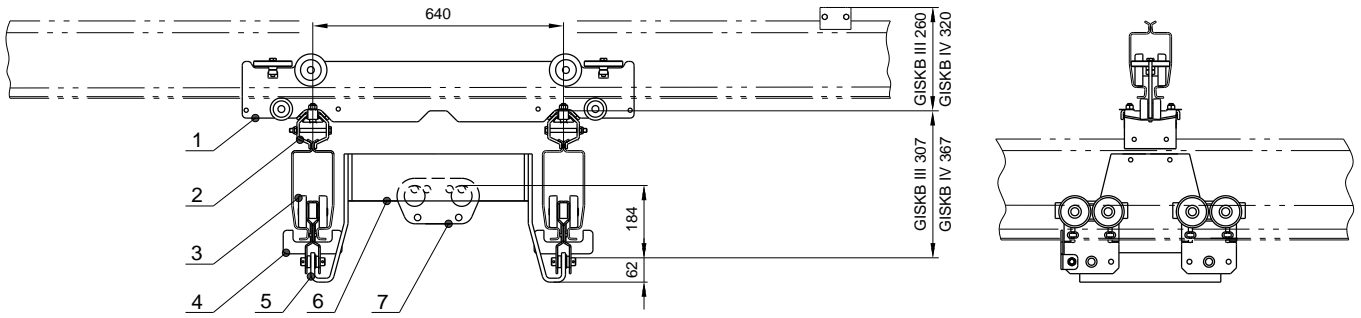

Crane track: GISKB III / GISKB IV, crane bridge: GISKB II

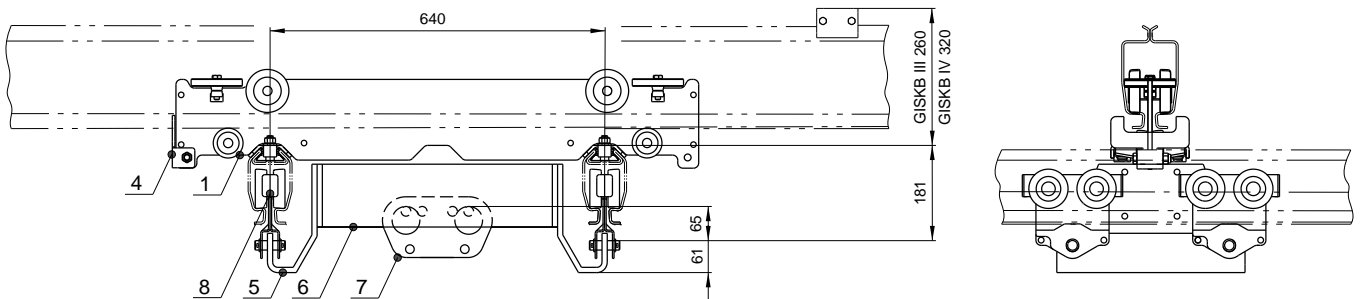

Crane track: GISKB II, crane bridge: GISKB III / GISKB IV

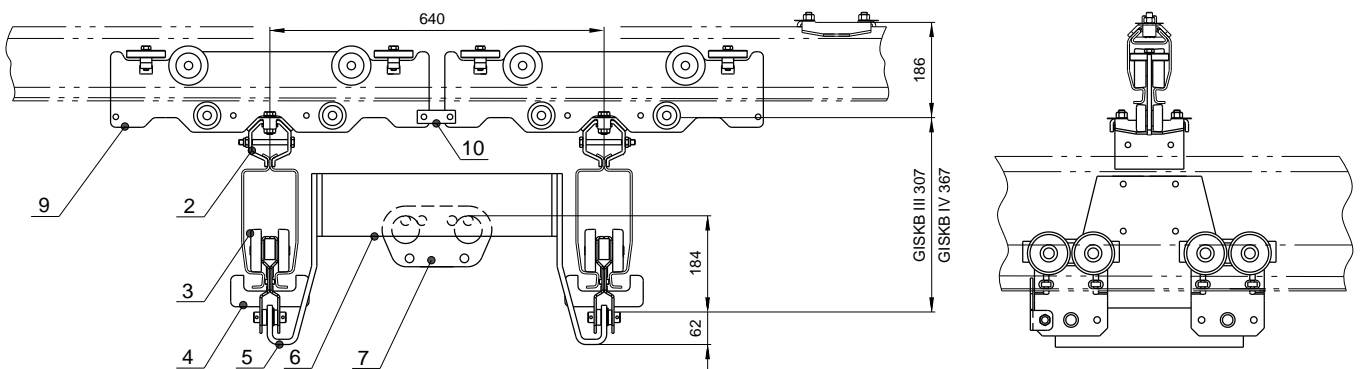

Item	Profile	 [kg]	 [kg]	Designation	N°
1	GISKB III + IV	15.000	1600	Rolling apparatus DQB	9307.1119.3
2	GISKB III + IV	0.500	1600	Profile retainer complete	9307.1055.3
3	GISKB III + IV	6.200	800	Trolley	9307.1002.3
4	GISKB III + IV	0.500	1600	Overload protection	9307.1108.4
5	GISKB III + IV	5.900	1600	Bracket saddle	9307.1100.3
	GISKB III + IV	8.800	1600	Bracket saddle above	9307.1101.3
6	GISKB III + IV	11.000	1600	Traverse saddle	9307.1104.3
7	GISKB III + IV	0.800	1000	Suspension part GCH 250/500	9401.3046.4
	GISKB III + IV	2.000	1600	Suspension part GCH 1000	9307.1103.3
	GISKB III + IV	2.800	1600	Suspension part GCH 1600/2000/2500	9408.3020.3
8	GISKB II	2.000	800	Trolley	9306.1020.3
9	GISKB II	6.500	1600	Rolling apparatus EQB	9306.1022.3
10	GISKB I + II	0.200	1600	Connector rolling apparatus complete	9307.1107.4

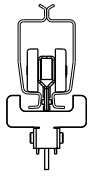
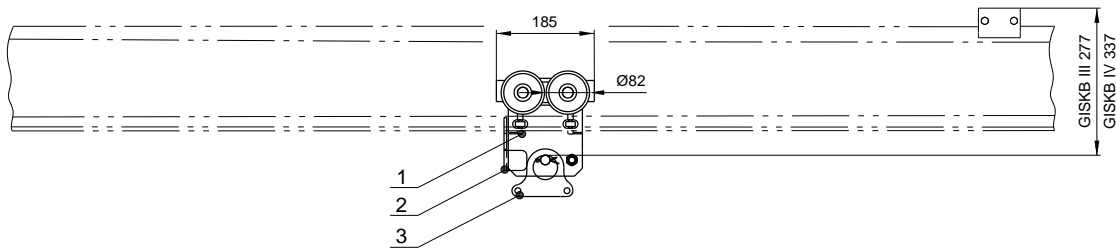

5.9 Overview monorail

Monorail: GISKB III / GISKB IV

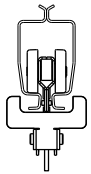
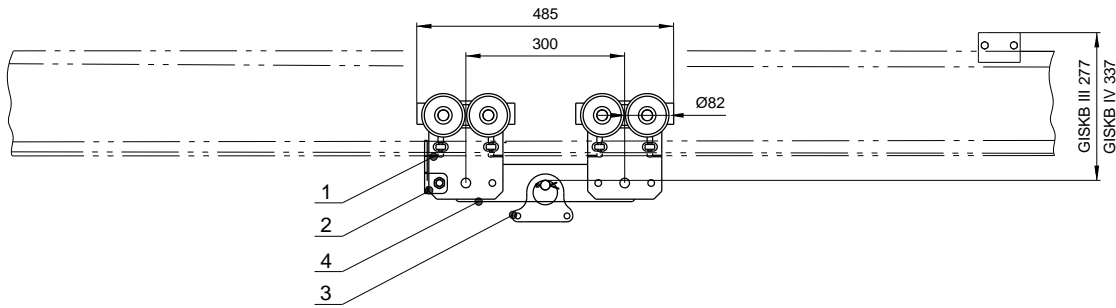

Monorail: GISKB III / GISKB IV



Item	Profile	 [kg]	 [kg]	Designation	N°
1	GISKB III + IV	6.200	800	Trolley	9307.1002.3
2	GISKB III + IV	0.500	1600	Overload protection	9307.1108.4
3	GISKB III + IV	0.600	1000	Eyebolt suspension GCH 250/500	9307.1052.4
	GISKB III + IV	1.100	1600	Eyebolt suspension GCH 1000	9307.1049.4
4	GISKB III + IV	3.400	1600	Traverse	9307.1006.3

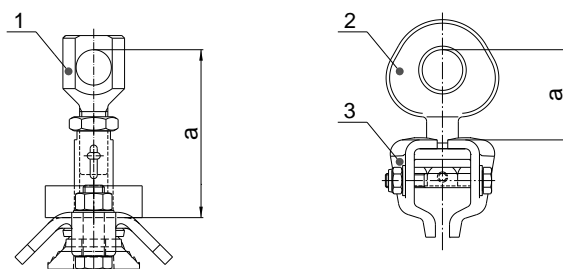

5.10 Crane-bridge suspension pendulating



Version.....: Steel, galvanised.

Use.....: For pendulating suspension of the crane bridge.

Note: The pendulating suspension of the crane bridge is possible only in connection with a pendulating crane track.

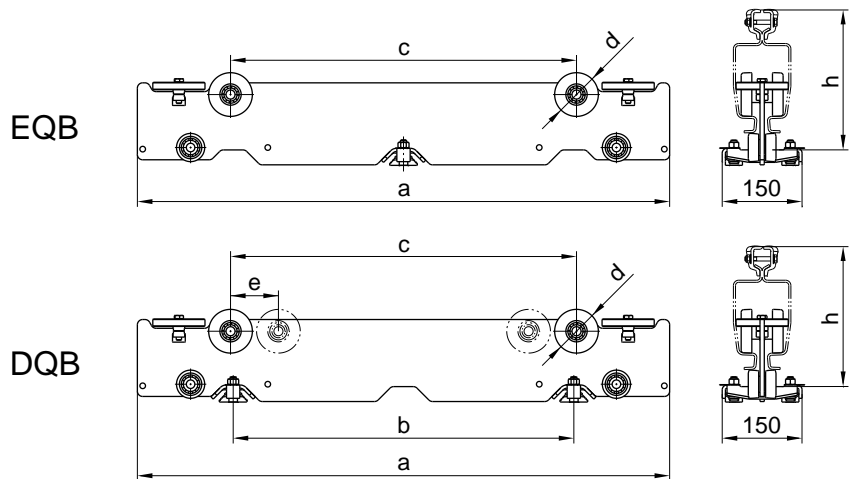

Item	 [kg]	 [kg]	a [mm]	Designation	N°
1	1.200	1600	92	Crane bridge suspension	9307.1050.4
2	0.600	1600	51	Articulated suspension	9307.1003.4
3	0.400	1600	51	Profile retainer complete	9307.1004.4

5.11 Rolling apparatus



Version: Steel, galvanised. The rolling apparatus is equipped with steel rollers. Lateral guide rollers and counter-pressure rollers prevent tilting up or over within the track section.

Use: Version EQB is used for single crane bridges, version DQB for double crane bridges. In both versions the crane bridge is installed permanently.

Profile	 [kg]	 [kg]	a [mm]	b [mm]	c [mm]	d [mm]	e [mm]	h [mm]		N°
GISKB III EQB	14.000	1600	1000	-	650	82	-	260		9307.1118.3
GISKB III DQB	15.000	1600	1000	640	650	82	-	260		9307.1119.3
GISKB III DQB	18.500	2400	1000	640	650	82	90	260		9307.1127.4
GISKB IV EQB	14.000	1600	1000	-	650	82	-	320		9307.1118.3
GISKB IV DQB	15.000	1600	1000	640	650	82	-	320		9307.1119.3
GISKB IV DQB	18.500	2400	1000	640	650	82	90	320		9307.1127.4

5.12 Reinforcement rolling apparatus

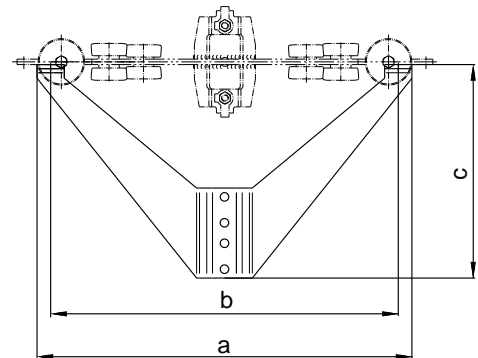

Version: Steel, galvanised. The reinforcement stabilises the connection from the crane bridge to the rolling apparatus and, thus, it improves the running property.

Use: The reinforcement is generally used for the rolling apparatus EQB.

Profile	 [kg]	a [mm]	b [mm]	c [mm]		N°
GISKB III + IV	3.000	550	510	313		9309.3135.3

5.13 Overload protection

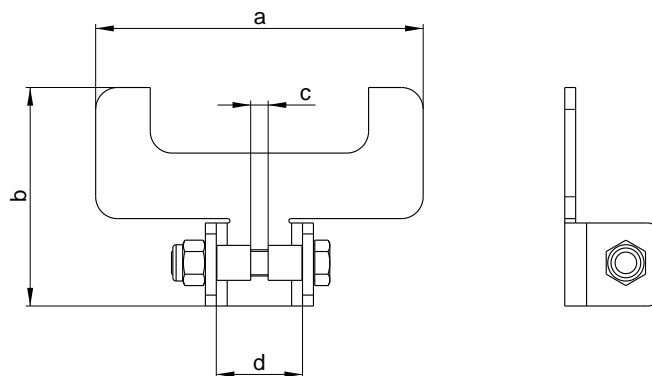

Version.....: Steel, galvanised.

Use.....: Prevents widening of the track section in case of overload of the trolley or rolling apparatus.

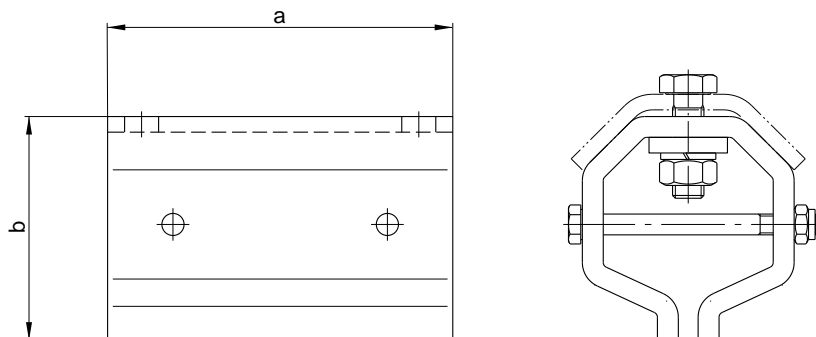

Profile	 [kg]	a [mm]	b [mm]	c [mm]	d [mm]		N°
GISKB III + IV	0.500	150	100	8	39.5		9307.1108.4

5.14 Profile retainer complete



Version.....: Steel, galvanised.

Use.....: Installation of a track section to a rolling apparatus.

Profile	 [kg]	 [kg]	a [mm]	b [mm]		N°
GISKB III + IV	0.500	1600	132	86		9307.1055.3

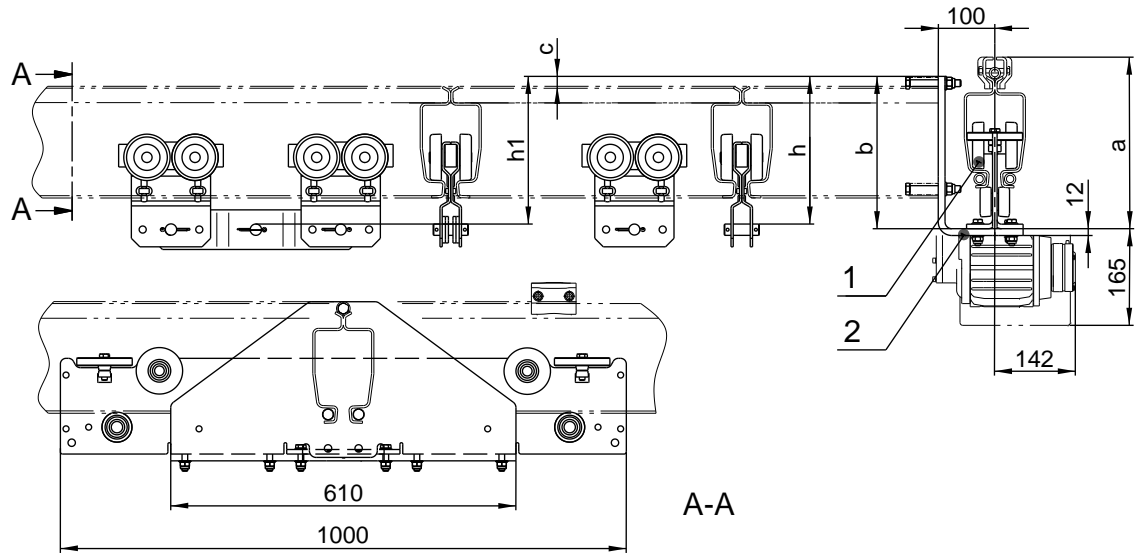

5.15 Breaker





Version: Steel, galvanised.

Use: Junction of rolling apparatus and crane bridge. The crane bridge is installed between the crane tracks. This reduces the construction height significantly.

Rolling apparatus (Item 1)

Profile	 [kg]	 [kg]		N°
GISKB I	8.400	800		9309.3184.2
GISKB II	9.800	1600		9309.3186.2
GISKB III + IV	19.600	1600		9309.3188.2

Bracket (Item 2)

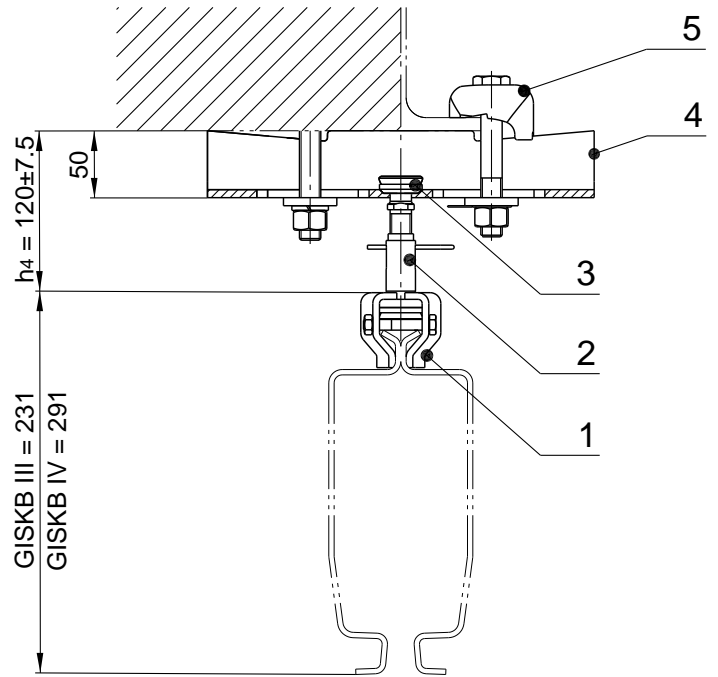

Crane track	Crane bridge	 [kg]	 [kg]	a [mm]	b [mm]	c [mm]	h [mm]	h1 [mm]	N°
GISKB I	GISKB III EQB	15.900	800	190	190	18	260	260	9309.3158.2
	GISKB III DQB	20.300	800	190	190	18	193	-	9309.3174.2
	GISKB IV EQB	15.900	800	190	190	18	320	320	9309.3158.2
	GISKB IV DQB	20.300	800	190	190	18	253	-	9309.3174.2
GISKB II	GISKB III EQB	16.800	800	229	229	18	260	260	9309.3160.2
	GISKB III DQB	21.700	800	229	229	18	193	-	9309.3176.2
	GISKB IV EQB	16.800	1600	229	229	18	320	320	9309.3160.2
	GISKB IV DQB	21.700	1600	229	229	18	253	-	9309.3176.2
GISKB III	GISKB III EQB	17.700	800	303	269	18	297	297	9309.3162.2
	GISKB III DQB	23.100	800	303	269	18	233	-	9309.3178.2
	GISKB IV EQB	17.700	1600	303	269	18	357	357	9309.3162.2
	GISKB IV DQB	23.100	1600	303	269	18	293	-	9309.3178.2
GISKB IV	GISKB III EQB	19.000	800	363	329	18	297	297	9309.3164.2
	GISKB III DQB	25.600	800	363	329	18	233	-	9309.3180.2
	GISKB IV EQB	19.000	1600	363	329	18	357	357	9309.3164.2
	GISKB IV DQB	25.600	1600	363	329	18	293	-	9309.3180.2

5.16 Suspension pendulating short adjustable



Version.....: Steel, galvanised. Ball pin (3) and ball nut (2) are screwed directly together to form the shortest pendulating suspension. Pendulating movements of max. 10° are permissible. The suspension can be adjusted by ± 7.5 mm.

Note: Please consider the guidelines for suspensions (see page 7).

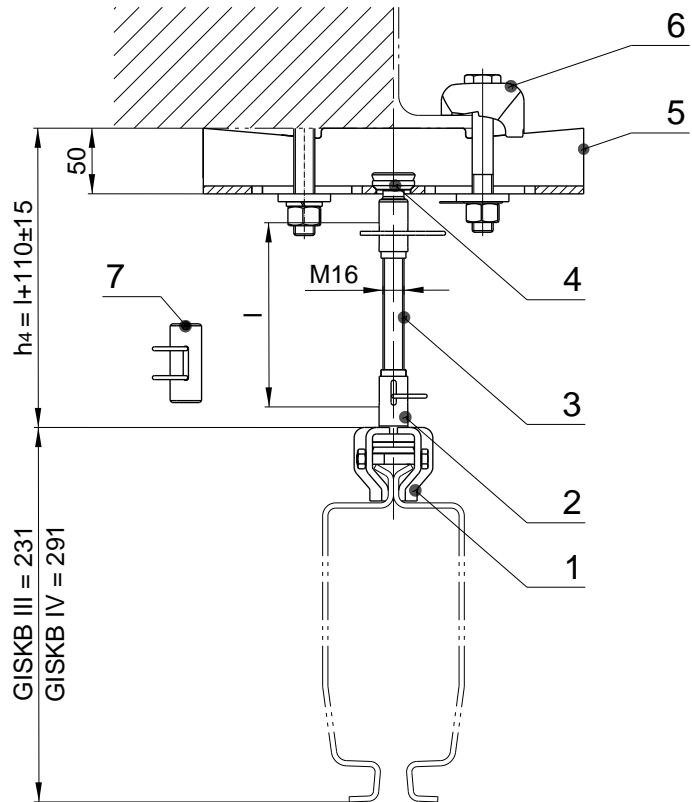

Item	 [kg]	 [kg]	Designation	N°
1	0.400	1600	Profile retainer complete	9307.1004.4
2	0.200	1600	Ball nut complete	9307.1068.4
3	0.120	1600	Ball pin complete	9309.3010.4
4	2.000	1600	Ceiling clip, flange width: 65 - 200 mm	9309.3003.3
	4.000	1600	Ceiling clip, flange width: 200 - 300 mm	9309.3112.3
5	0.600	800	Binding clip complete, flange width: 65 - 200 mm	9309.3005.4
	0.650	800	Binding clip complete, flange width: 200 - 300 mm	9309.3113.4

5.17 Suspension pendulating distanced adjustable



Version.....: Steel, galvanised. The threaded rod (3) which is variable in length forms with two screwed ball nuts (2, 4) the distanced suspension. With the suspension height differences of ± 15 mm can be adjusted. With the coupling (7), two threaded rods can be connected.

Note.....: For distanced suspensions greater than or equal to $h_4 = 500$ mm (see page 10) bracings are provided. Please consider the guidelines for suspensions (see page 7).

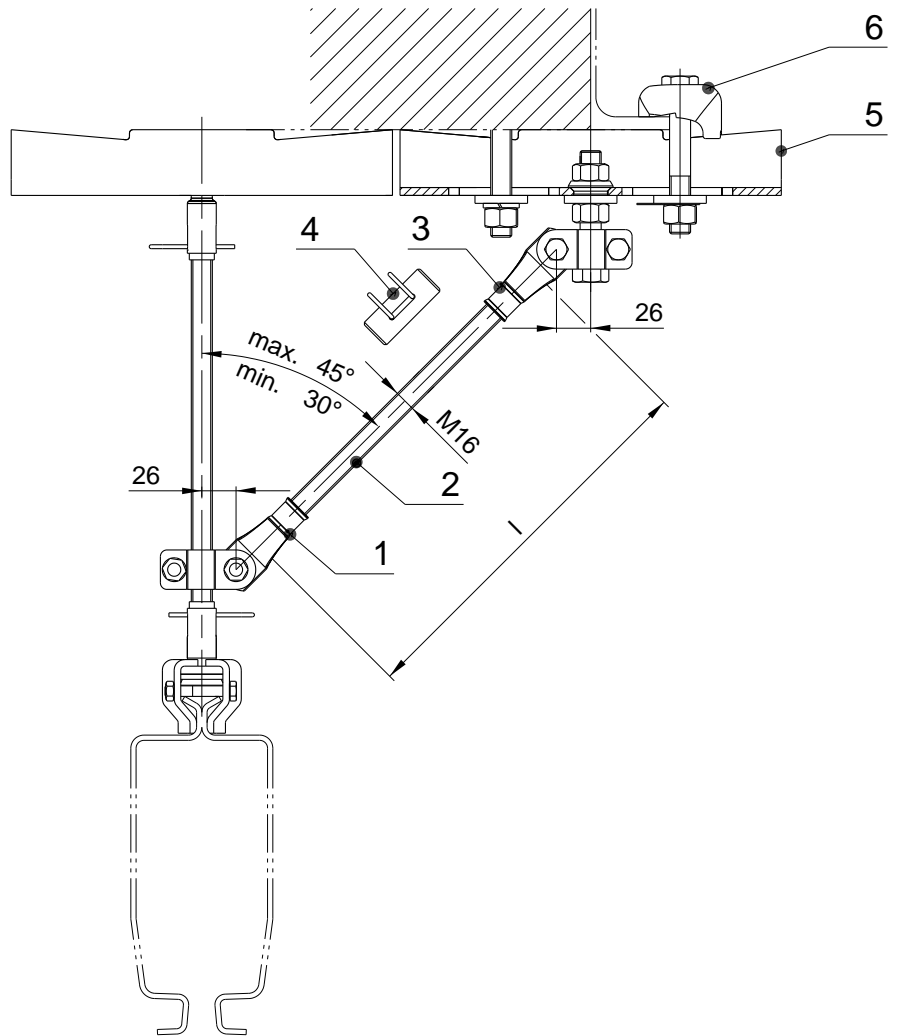

Item	 [kg]	 [kg]	Designation	N°
1	0.400	1600	Profile retainer complete	9307.1004.4
2	0.200	1600	Ball nut complete	9307.1068.4
3	0.100	1600	Threaded rod, l = 100 mm	9309.3024.4
	0.200	1600	Threaded rod, l = 200 mm	9309.3025.4
	0.400	1600	Threaded rod, l = 300 mm	9309.3026.4
	0.650	1600	Threaded rod, l = 500 mm	9309.3027.4
	1.200	1600	Threaded rod, l = 1000 mm	9309.3028.4
4	0.160	1600	Ball nut complete	9309.3011.4
5	2.000	1600	Ceiling clip, flange width: 65 - 200 mm	9309.3003.3
	4.000	1600	Ceiling clip, flange width: 200 - 300 mm	9309.3112.3
6	0.600	800	Binding clip complete, flange width: 65 - 200 mm	9309.3005.4
	0.650	800	Binding clip complete, flange width: 200 - 300 mm	9309.3113.4
7	0.150	1600	Coupling complete	9309.3033.4

5.18 Bracing pendulating distanced adjustable



Version.....: Steel, galvanised. The bracing is composed of the knots below (1) and the knots above (3) connected to a threaded rod (2). The length of the threaded rod is the same as for the suspension.

Note: Please consider the guidelines for suspensions (see page 7).

Item	 [kg]	 [kg]	Designation	N°
1	0.300	1600	Lower knots	9309.3015.4
2	0.100	1600	Threaded rod, l = 100 mm	9309.3024.4
	0.200	1600	Threaded rod, l = 200 mm	9309.3025.4
	0.400	1600	Threaded rod, l = 300 mm	9309.3026.4
	0.650	1600	Threaded rod, l = 500 mm	9309.3027.4
	1.200	1600	Threaded rod, l = 1000 mm	9309.3028.4
3	0.600	1600	Upper knots	9309.3016.4
4	0.150	1600	Coupling complete	9309.3033.4
5	2.000	1600	Ceiling clip, flange width: 65 - 200 mm	9309.3003.3
	4.000	1600	Ceiling clip, flange width: 200 - 300 mm	9309.3112.3
6	0.600	800	Binding clip complete, flange width: 65 - 200 mm	9309.3005.4
	0.650	800	Binding clip complete, flange width: 200 - 300 mm	9309.3113.4

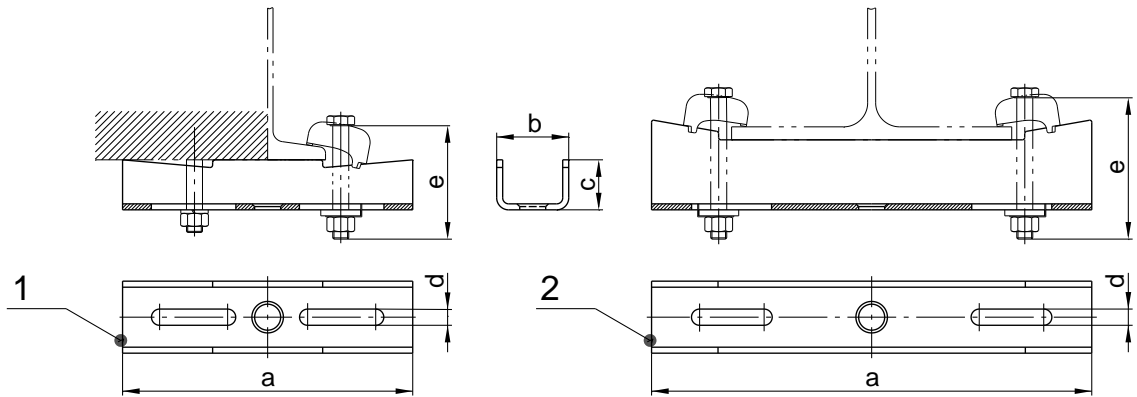

5.19 Ceiling clip



Version: Steel, galvanised.

Use: Suspension on steel construction (Item 1, Item 2) and flat concrete ceiling (Item 1).

Note: Fixing material for flat concrete ceilings is not delivered by us: Please contact specialised dealer. The ceiling clip (Item 2) is not suitable for assembly on to flat concrete ceilings.

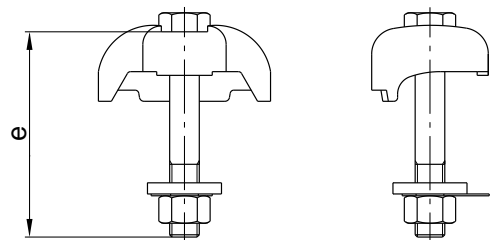

Item	Profile	 [kg]	 [kg]	 [mm]	a [mm]	b [mm]	c [mm]	d [mm]	e [mm]	N°
1	GISKB III + IV	2.000	1600	65 - 200	290	72	50	16.2	110	9309.3003.3
2	GISKB III + IV	4.000	1600	200 - 300	440	72	70	16.2	150	9309.3112.3

5.20 Binding clip complete



Version: Steel, galvanised.

Use: Suspension on steel structure.

Profile	 [kg]	 [kg]	e [mm]	Designation	N°
GISKB III + IV	0.600	800	110	Binding clip compl. ceiling clip 65-200 mm	9309.3005.4
GISKB III + IV	0.650	800	150	Binding clip compl. ceiling clip 200-300 mm	9309.3113.4

5.21 Support to ceiling clip

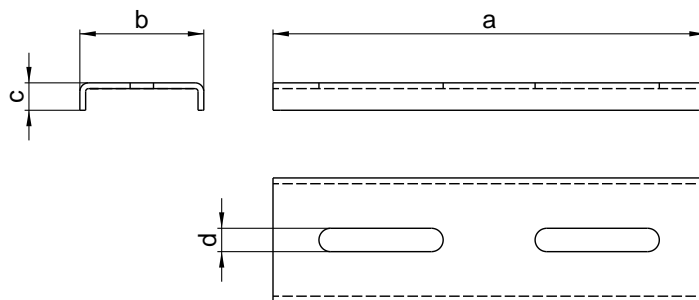

Version.....: Steel, galvanised.

Use.....: Suspension on flat concrete ceiling or on concrete ceiling with cast-in steel rails (Halfen, Jordal).

Profile	 [kg]	a [mm]	b [mm]	c [mm]	d [mm]		N°
GISKB III + IV	1.000	300	86	19	16.2		9309.3115.3

5.22 Lateral suspension

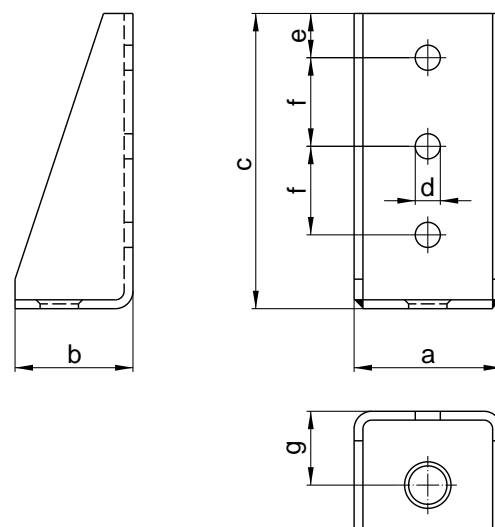

Version.....: Steel, galvanised.

Use.....: Lateral suspension to wooden truss or concrete applications.

Note: Fixing material is not delivered by us: Please contact specialised dealer.

Profile	 [kg]	a [mm]	b [mm]	c [mm]	d [mm]	e [mm]	f [mm]	g [mm]		N°
GISKB III + IV	2.000	100	80	200	17	30	60	50		9309.3111.3

5.23 GIS adhesive

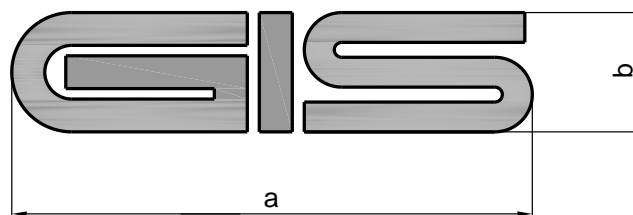

Version: Grey, self-adhesive.

Use: Crane bridge, monorail.

Type	Profile	a [mm]	b [mm]		N°
Middle	GISKB III + IV	260	60		9309.5076.4

5.24 Lifting capacity adhesive

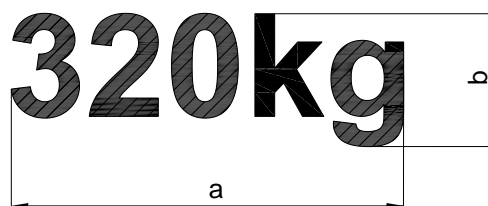

Version: Black, self-adhesive.

Use: Crane bridge, monorail.

Type	Profile	 [kg]	a [mm]	b [mm]		N°
Middle	GISKB III + IV	80	180	60		9309.5099.4
	GISKB III + IV	100	180	60		9309.5100.4
	GISKB III + IV	125	180	60		9309.5101.4
	GISKB III + IV	160	180	60		9309.5102.4
	GISKB III + IV	200	180	60		9309.5103.4
	GISKB III + IV	250	180	60		9309.5104.4
	GISKB III + IV	320	180	60		9309.5105.4
	GISKB III + IV	400	180	60		9309.5106.4
	GISKB III + IV	500	180	60		9309.5107.4
	GISKB III + IV	630	180	60		9309.5108.4
	GISKB III + IV	800	180	60		9309.5109.4
	GISKB III + IV	1000	210	60		9309.5110.4
	GISKB III + IV	1250	210	60		9309.5111.4
	GISKB III + IV	1600	210	60		9309.5112.4
GISKB III + IV	2000	210	60		9309.5113.4	

5.25 Electric tug

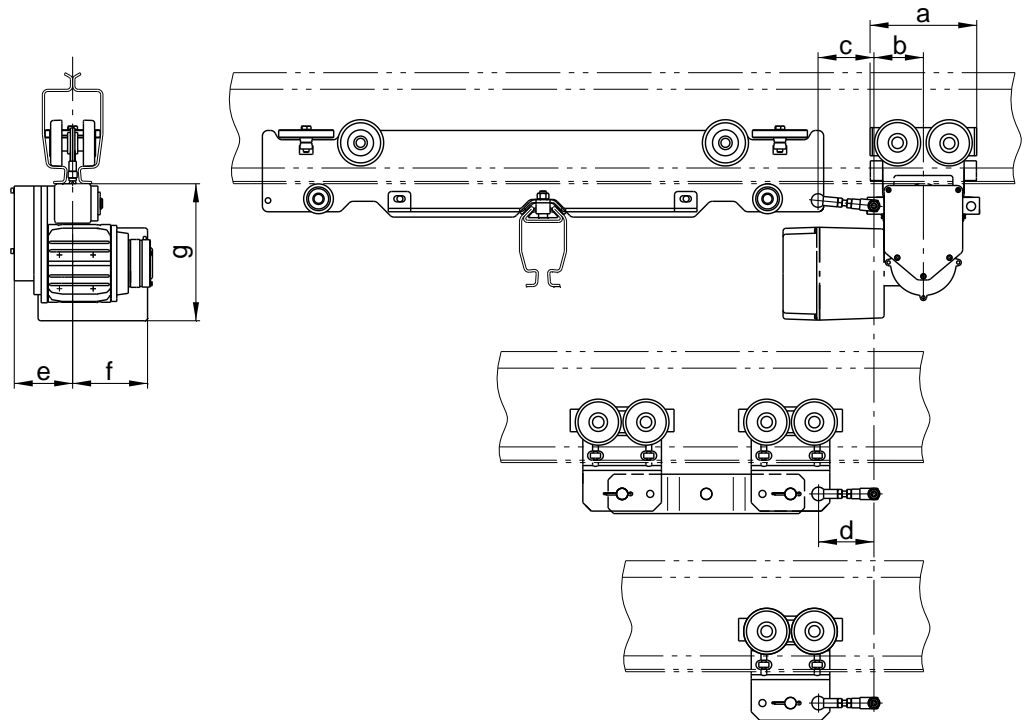

Version.....: Friction roller drive. Trolley galvanised and equipped with plastic rollers, gear housing and motor in black finish. Controlled by frequency converter (FU) and equipped with brake as standard.

Use.....: Electric drive for cross and long travel in GISKB III + IV.

Note: Connector clamp to trolley and rolling apparatus have to be ordered separately. When the crane bridge is moved electrically, a rigid crane bridge suspension must always be selected (see page 16 - 17).

Profile	 [kg]	a [mm]	b [mm]	c [mm]	d [mm]	e [mm]	f [mm]	g [mm]	N°
GISKB III + IV	15.100	190	90	100	100	104	134	244	SAKB3/4.BR/FU
GISKB III + IV	14.600	190	90	100	100	104	134	244	SAKB3/4.BR

Type specification and technical data:

Type	Profile	 [kg]	Speed [m/min]	Power [kW]	3 x 400 V 50 Hz [A]	%duty / S/h	Version
SAKB3/4.BR/FU	GISKB III + IV	800	3-12 / 3-35	0.25	0.8	60 / 360	with control
SAKB3/4.BR	GISKB III + IV	800	3-12 / 3-35	0.25	0.8	60 / 360	without control

A single electric tug can move loads up to 1600 kg if used for a monorail.

The ramps and speeds are factory-set (6/35 m/min). However, these can be customised by trained personnel. The adjustable frequency is min. 8 Hz (3 m/min) to max. 87 Hz (35 m/min).

The electric tug is available for the following operating voltages: 400-480 V 50/60 Hz, 208-240 V 50/60 Hz, 500-575 V 50/60 Hz.

5.26 Connector clamp

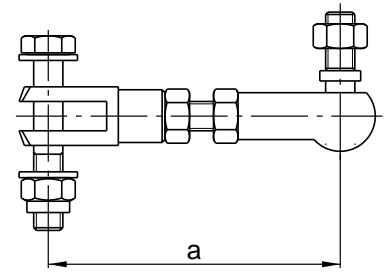

Version.....: Steel, galvanised.

Use.....: Connection of electric tug and trolley or rolling apparatus.

Profile	 [kg]	a [mm]		N°
GISKB III + IV	0.200	100		9307.1115.4

6 Power supply

6.1 Trailing cable

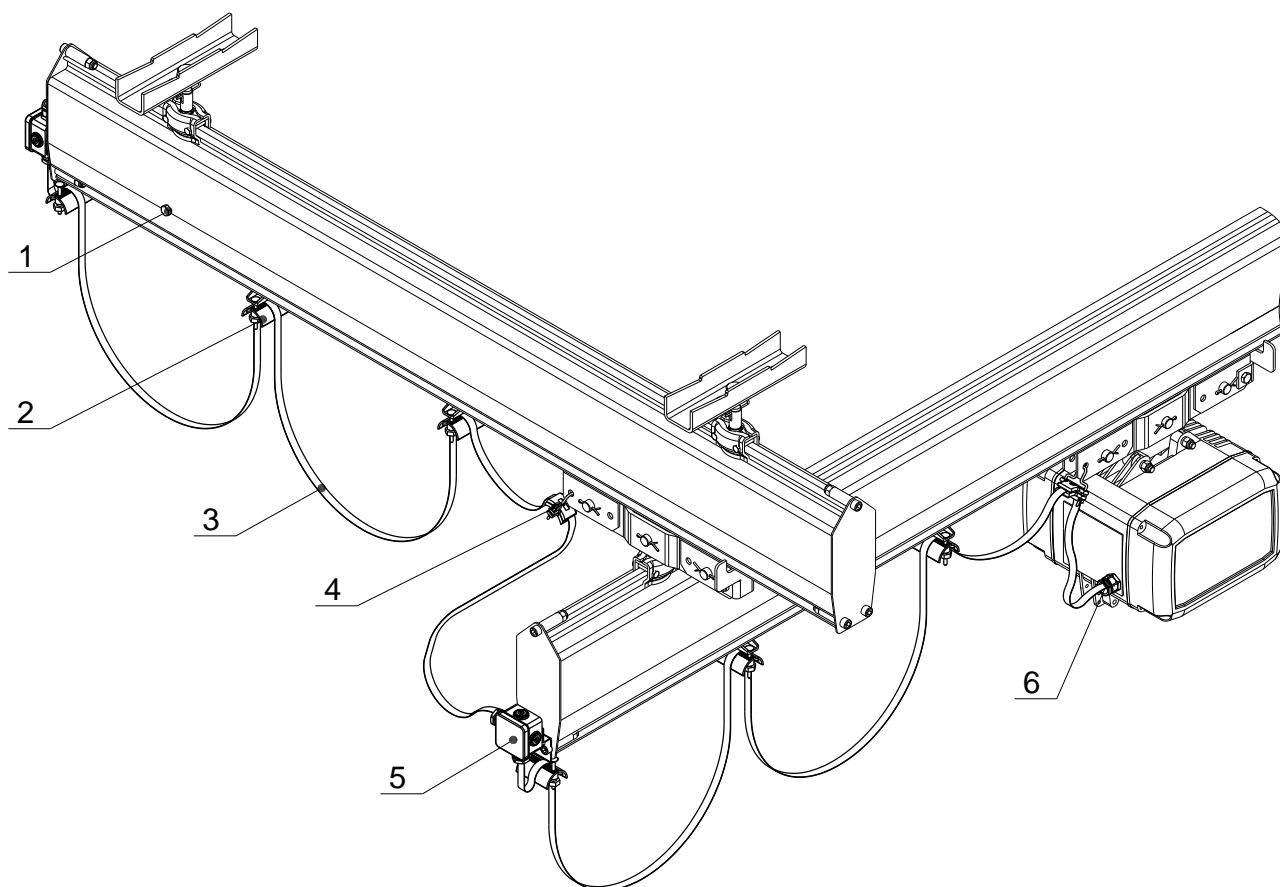

Item	 [kg]	Designation	N°
1	0.100	Traction limit	9307.1060.4
2	0.150	Cable carriage	9307.1005.3
3	0.130	Flat cable, 4 x 1.5 mm ²	9055.0300
4	0.040	Cable fixing part	9309.3069.4
5	0.300	Terminal box complete	9307.1096.4
6	0.050	Cable gland, M25 x 1.5, FK, PVC	9055.3107

6.2 C rail

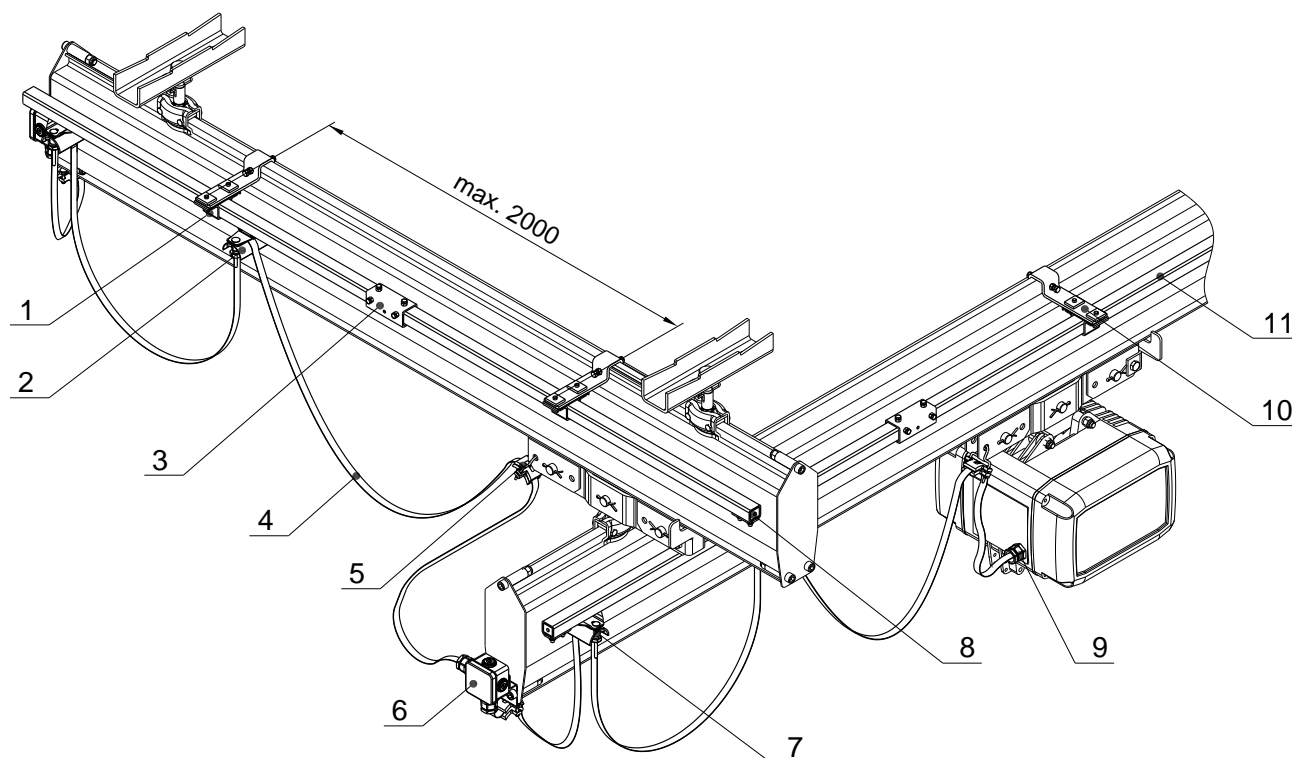

Item	 [kg]	Designation	N°
1	0.250	Suspension	9057.4200
2	0.300	Cable carriage	9057.4250
3	0.300	Connector	9057.4150
4	0.130	Flat cable, 4 x 1.5 mm ²	9055.0300
5	0.040	Cable fixing part	9309.3069.4
6	0.300	Terminal box complete	9307.1096.4
7	0.200	Cable end clamp	9057.4100
8	0.150	C-rail stop	9057.4300
9	0.050	Cable gland, M25 x 1.5, FK, PVC	9055.3107
10	0.950	Clamping device complete, a = 300	9307.1009.4
11	1.500	C rail, 1 m	9309.3046.4
	3.000	C rail, 2 m	9309.3047.4
	4.500	C rail, 3 m	9309.3048.4
	6.000	C rail, 4 m	9309.3049.4
	7.500	C rail, 5 m	9309.3050.4
	9.000	C rail, 6 m	9309.3051.4

6.3 Conductor line

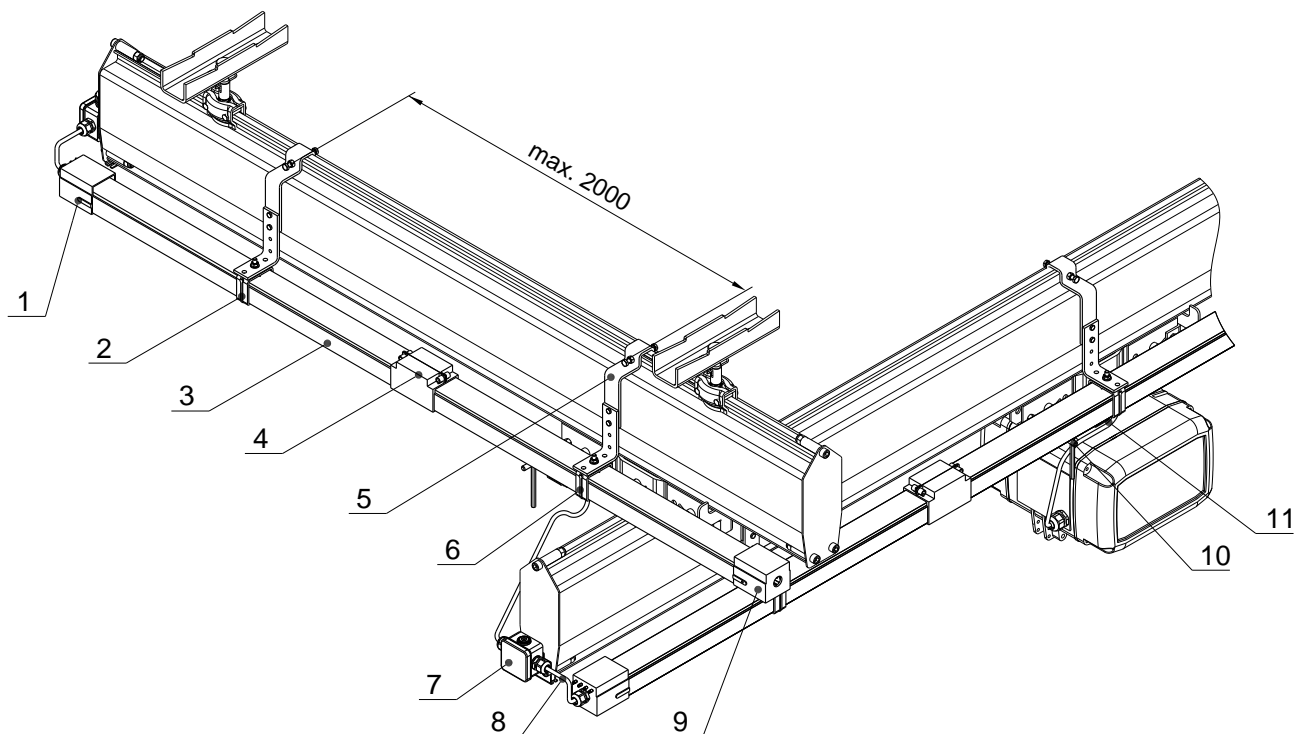

Item	 [kg]	Designation	N°
1	0.100	Power feed, EVD4	9309.3127.4
2	0.050	Suspension, VA806	9057.0103
3	1.100	Conductor line VA24, 4-pin, 1 m	9309.3058.4
	2.200	Conductor line VA24, 4-pin, 2 m	9309.3059.4
	3.300	Conductor line VA24, 4-pin, 3 m	9309.3060.4
	4.400	Conductor line VA24, 4-pin, 4 m	9309.3061.4
	5.500	Conductor line VA24, 4-pin, 5 m	9309.3062.4
4	0.100	Connection cap, VA804	9057.0552
5	0.900	Holder conductor line	9307.1097.3
6	0.050	Fixed suspension, VA850	9057.0104
7	0.300	Terminal box complete	9307.1096.4
8	0.200	Connection cable	9309.3071.4
9	0.100	End cap, VA802	9057.0151
10	0.110	Driving pin	9309.3070.4
11	0.600	Current collector trolley, PM425C, Standard	9057.0400

Customer data			
Company _____		Date _____	
Address _____		Customer number _____	
Postal code _____		Phone number _____	
City - Country _____		Fax number _____	
Responsible person _____		Function _____	
Crane system GISKB			
<input type="checkbox"/> Single crane bridge		<input type="checkbox"/> Double crane bridge	<input type="checkbox"/> Suspended track
Load capacity _____ kg			
Length of the girder L _____ mm		Length of the track B _____ mm	
Span W _____ mm		Height of the room _____ mm	
Required lifting height _____ mm		Sketch see on back !	
Suspension			
Kind of suspension		<input type="checkbox"/> pendulating short	<input type="checkbox"/> pendulating from rod _____ mm
		<input type="checkbox"/> rigid	
Ceiling construction		<input type="checkbox"/> Concrete ceiling	<input type="checkbox"/> Steel girder _____
		<input type="checkbox"/> Wooden truss _____	
Suspension distance		<input type="checkbox"/> variable	<input type="checkbox"/> given _____ mm
Travelling motions			
Movement of the trolley		<input type="checkbox"/> push type	<input type="checkbox"/> electrical type
		<input type="checkbox"/> 1 speed	<input type="checkbox"/> 2 speeds
			<input type="checkbox"/> _____ m/min
Movement of the bridge		<input type="checkbox"/> push type	<input type="checkbox"/> electrical type
		<input type="checkbox"/> 1 speed	<input type="checkbox"/> 2 speeds
			<input type="checkbox"/> _____ m/min
Hoist			
<input type="checkbox"/> GIS Electric chain hoist		<input type="checkbox"/> Hand lifting gear	<input type="checkbox"/> _____
Type _____		Lifting capacity _____ kg	
Lifting speed		<input type="checkbox"/> 1 speed	<input type="checkbox"/> 2 speeds
			<input type="checkbox"/> _____ m/min
Lifting height (standard 3 m) _____ m		Operating time per day _____ hours	
Control / Electricity			
Control		<input type="checkbox"/> Operation from control switch of hoist	<input type="checkbox"/> Ideal control (control switch is movable independently)
Voltage		<input type="checkbox"/> 3 Ph 400V, 50Hz	<input type="checkbox"/> 1 Ph 230V, 50Hz
			<input type="checkbox"/> _____ V _____ Hz
Longitudinal power supply		<input type="checkbox"/> without	<input type="checkbox"/> Trailing cable
		<input type="checkbox"/> Contact line	<input type="checkbox"/> C-rail
Transversal power supply		<input type="checkbox"/> without	<input type="checkbox"/> Trailing cable
		<input type="checkbox"/> Contact line	<input type="checkbox"/> C-rail
Location of the crane			
<input type="checkbox"/> Workshop		<input type="checkbox"/> outdoor	<input type="checkbox"/> near acids/alkaline solutions
<input type="checkbox"/> _____			
Installation			
<input type="checkbox"/> by GIS		<input type="checkbox"/> by customers	<input type="checkbox"/> Stacker truck is available at building site
Additional technical data/Customer requirements			
Required offer			
<input type="checkbox"/> Short offer		<input type="checkbox"/> Approximate price	<input type="checkbox"/> Offer required by _____
<input type="checkbox"/> Detailed offer		<input type="checkbox"/> Date of realisation / desired delivery time _____	
GIS AG		Enclosures	
swiss lifting solutions		<input type="checkbox"/> Sketch _____	
CH - 6247 Schötz		<input type="checkbox"/> Plan/Drawing _____	
Phone +41 (0)41 984 11 33		<input type="checkbox"/> _____	
E-mail tel@gis-ag.ch			

