

TRANSLATION OF THE ORIGINAL INSTRUCTION AND ASSEMBLY MANUAL

Crane components ERK

GIS CRANES

+ SWISS QUALITY

ERK 50

ERK 150

ERK 300

ERK 500

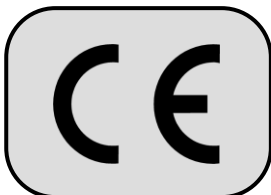

M A D E I N S W I T Z E R L A N D

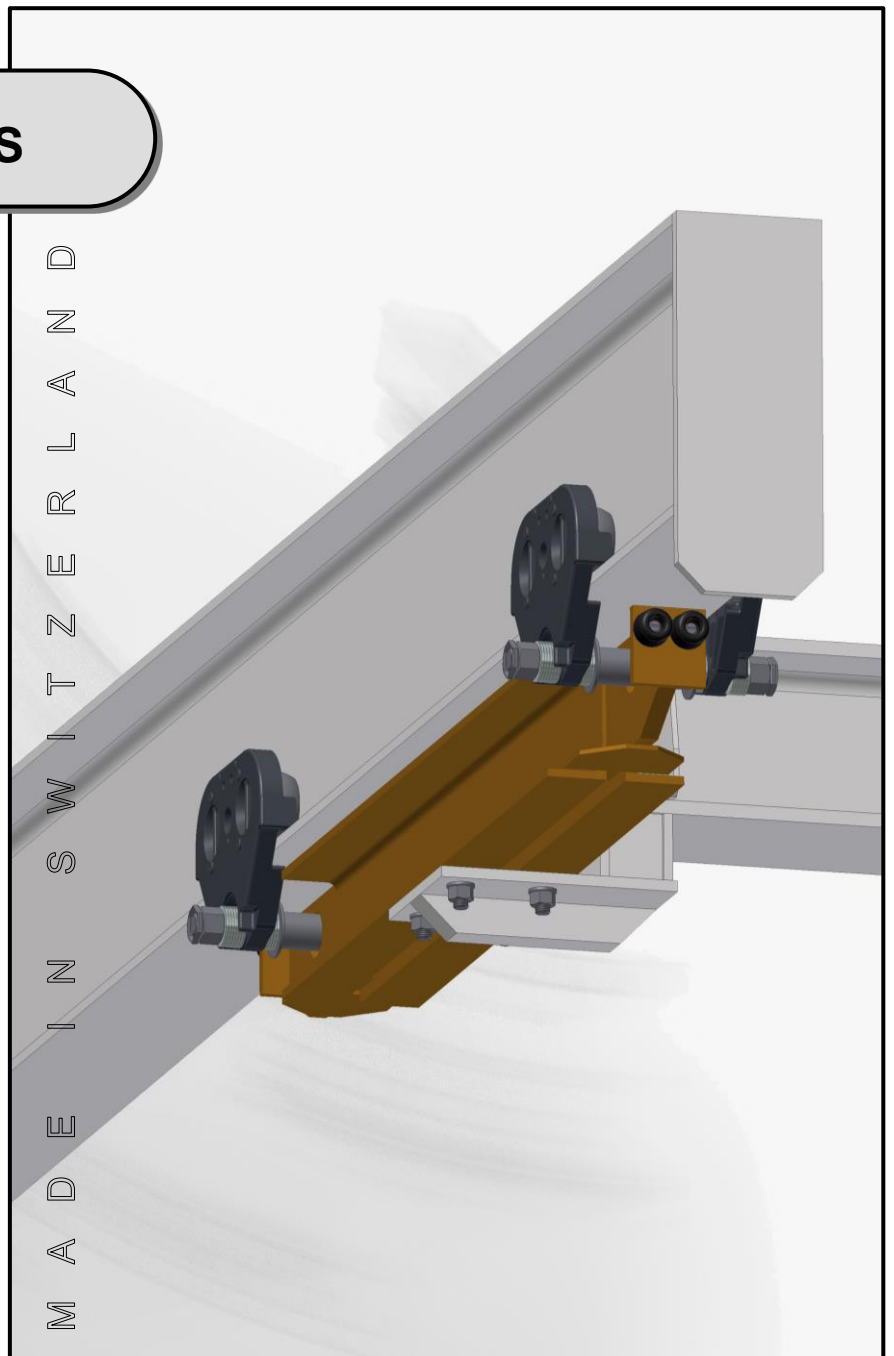

Table of contents

0	General information.....	3
0.1	General safety information	3
0.1.1	Safety and hazard precautions	3
0.2	General safety specifications and procedures	3
0.3	Special safety directions.....	3
0.4	Notes on hazard protection	4
0.4.1	Hazards caused by mechanical influences	4
0.5	Technical status	4
0.5.1	Technical data.....	4
0.5.2	Recurrent checks	4
0.5.3	Warranty	4
0.6	Operational parameters.....	5
0.6.1	Directions for using the instruction manual	5
1	Description	5
1.1	Operating conditions	5
1.2	General description	5
2	Assembly instructions	5
2.1	Transport and assembly	6
2.2	Assembly	6
3	Appendix.....	7
3.1	EC Declaration of incorporation.....	7

0 General information

0.1 General safety information

0.1.1 Safety and hazard precautions

The following symbols and terms are used in this instruction manual for safety and hazard instructions:



DANGER !

Non-compliance, either in part or full, with operating instructions marked with this symbol can result in serious personal injury or even death. Danger notices must be **strictly** complied with.



CAUTION !

Non-compliance, either in part or full, with operating instructions marked with this symbol can result in major damage to machinery, property or material.

Cautionary notices must be **strictly** adhered to.



NOTE

Following the instructions marked by this symbol will lead to more effective and straightforward operation.

"Note" directions make work easier.

0.2 General safety specifications and procedures

The instruction manual for the crane system must always be available within the operating area of the crane. The instructions mentioned in this manual must be strictly adhered to.

Furthermore, supplementary to the instruction manual, the statutory regulations governing general accident prevention and environmental protection are to be enforced.

Operating and service personnel must have read and understood the instruction manual, in particular the safety instructions, before commencing work. Protective equipment must be made available for operating and maintenance personnel and worn at all times. The operator or his representative is responsible for supervising operating personnel and ensuring they are aware of the hazards and safety implications of working with the crane system.

0.3 Special safety directions

Transport and assembly:

- Single parts and larger assemblies should be carefully affixed to suitable and technically acceptable hoisting apparatus / load lifting members with sufficient load capacity

Start-up / operation:

- Before initial start-up, as well as daily start-up, carry out a visual check and carry out the predefined user-checks routine
- Refrain from hazardous mode of operation
- The maximum load of ERK crane components must not be exceeded

Cleaning / service / repair / maintenance / refitting:

- Use the working platforms and ladders provided for assembly work above body height
- Do not use machine parts as an access aid
- Check electrical cables for damage or wear
- Reassemble and check safety installations that has been disassembled for servicing or repairing the hoist once service and repair work has been completed
- Adhere to predefined testing- and service intervals specified in the instruction manual
- Follow the directions in the instruction manual regarding exchanging parts
- Operating personnel should be informed before starting special or refitting work
- Secure the repair working area
- Attach warning signs
- Retighten screw connections that have been loosened for repair or service work
- Replace parts that are not reusable, such as self-locking nuts, gaskets, split-pins, O-rings and washers

0.4 Notes on hazard protection

Hazardous areas must be clearly marked by warning signs and safety fences. It must be ensured that warnings regarding hazardous areas are given due attention.

Hazards can stem from:

- incorrect application
- not following safety directions properly
- not carrying out test and maintenance work thoroughly

0.4.1 Hazards caused by mechanical influences

Physical injury:



DANGER !

Unconsciousness and injury through:

- crushing, shearing, cutting and twisting
- drawing in, ramming, piercing and rubbing
- slipping, stumbling and falling

Causes:

- Crushing, shearing and twisting areas
- parts breaking or bursting

Safety options:

- Keep floor, equipment and machinery clean
- observe the required safety distances

0.5 Technical status

The present document was written in 2012. It corresponds to directive 2006/42/EC of the European Parliament and of the Council of 17 May 2006.

0.5.1 Technical data

- 0.5.1.1 Models ERK 50 drawing 9248.9216.1, see appendix
- 0.5.1.2 Models ERK 150 drawing 9248.9221.1, see appendix
- 0.5.1.3 Models ERK 300 drawing 9248.9222.1, see appendix
- 0.5.1.4 Models ERK 500 drawing 9248.9237.1, see appendix

0.5.2 Recurrent checks

Each device/ unit operator should adequately note all checks, maintenance and inspections performed in the log book, and have these confirmed by the competent person in charge.

Incorrect or missing entries will lead to forfeiture of the manufacturer's warranty.



CAUTION !

Equipment and cranes are to be checked periodically by a specialist. Primarily visual and functional checks are to be carried out, whereby the condition of components with respect to damage, wear, corrosion or any other changes are determined. In addition, safety equipment is assessed for completeness and efficiency.

It may be necessary to disassemble the equipment to correctly assess wear parts.



CAUTION !

All periodical checks should be arranged by the operator.

0.5.3 Warranty

- The warranty is void if the installation, operation, testing or service is not carried out according to these instructions
- Troubleshooting and repair under warranty may only be carried out by qualified persons and only after consultation and agreement with the manufacturer / supplier. Any modifications to the product or the use of non-original spare parts will void the warranty

0.6 Operational parameters

The crane components of the series ERK are used as an end carriage for standard bottom flange travelling cranes. The crane components are manufactured in accordance with the latest technical developments and recognised safety standards, and are tested for safe operation by the manufacturer.

The crane components ERK shall only be used together with standard GIS trolleys. Crane components of the above series may only be used when in a flawless technical condition, in accordance with their intended use, by trained personnel in a safe and responsible manner. No changes that deteriorate the strength values shall be made to the crane components.

The intended use of the crane components likewise assumes the adherence to the maintenance conditions prescribed by the manufacturer. When calculating the maximum permissible payload, the weight of the crane bridge and the additional load through the length of the load have to be taken into account.

The operational parameters do not include:

- the defined maximum load is exceeded
- Pulling loads
- the loads break away, are pulled or dragged

See also chapter 0.3.

0.6.1 Directions for using the instruction manual

This instruction manual includes the following chapters:

- 0 General information
- 1 Description
- 2 Assembly instructions
- 3 Appendix

1 Description

General:

The ERK series comprises the following models:
ERK 50, ERK 150, ERK 300, ERK 500

1.1 Operating conditions

Classification according to application requirements:

The ERK components are not classified according to DIN 15018 and can be used for cranes of all classifications.

1.2 General description

The ERK components are designed as a crane-bridge kit.

For the construction of a bottom flange travelling crane a kit is required. The individual components can be found on the technical data sheets 9248.9216.1; 9248.9221.1; 9248.9222.1; 9248.9237.1. The ERK type is defined by the maximum permissible payload and the range of the crane bridge.



CAUTION !

The respective standard trolleys from GIS are to be used as longitudinal trolleys. See following table:

ERK 50.....:	EHF 50; EMFE 50
ERK 150....:	EHF 150; EMFE 150
ERK 300....:	EHF 300; EMFE 300
ERK 500....:	EHF 500; EMFE 500

2 Assembly instructions



DANGER !

Mechanical adjustments may only be performed by authorised specialists.



CAUTION !

The operating personnel must read the instruction manual thoroughly before the assembly of the crane components. Unauthorised persons may not assemble the crane components or carry out work with it.



CAUTION !

The operator must create an inspection log book when start-up the electric chain hoist. The log book contains all technical data and the start-up date. It provides a record of all servicing and maintenance work.

2.1 Transport and assembly

The safety instructions for handling of loads should be followed (see chapter 0.3) when transporting and assembling the crane components. The crane components must be assembled by qualified staff, always bearing in mind the accident prevention directions in chapter 0.2. Before the assembly the crane components must be stored in an enclosed room or covered area.

2.2 Assembly



CAUTION !

Before the assembly of the crane components it needs to be checked whether the type corresponds with the specifications on the technical data sheet and whether the type is suitable for the crane system to be installed.

- First, the end carriages are mounted to the crane bridge. The corresponding holes have to be drilled by the crane manufacturer according to the specifications on the technical data sheet. The provided connecting bolts have to be tightened with a torque key:

M 12	M 16	M 20
83 Nm	200 Nm	390 Nm

- On the front side of the end carriage 2 absorbers are mounted.
- Only original GIS trolleys may be used as push trolleys (see also chapter 0.6). It needs to be ensured that one side is designed as a fixed bearing. The provided spacer tubes are mounted between the big washers of the spindle and the end carriage.
- The opposite side is designed as a floating bearing, in order to compensate for inaccuracies in the crane runway.

See figure 2-1 ERK 50/150 and figure 2-2 ERK 300/500.

Figure 2-1 ERK 50/150

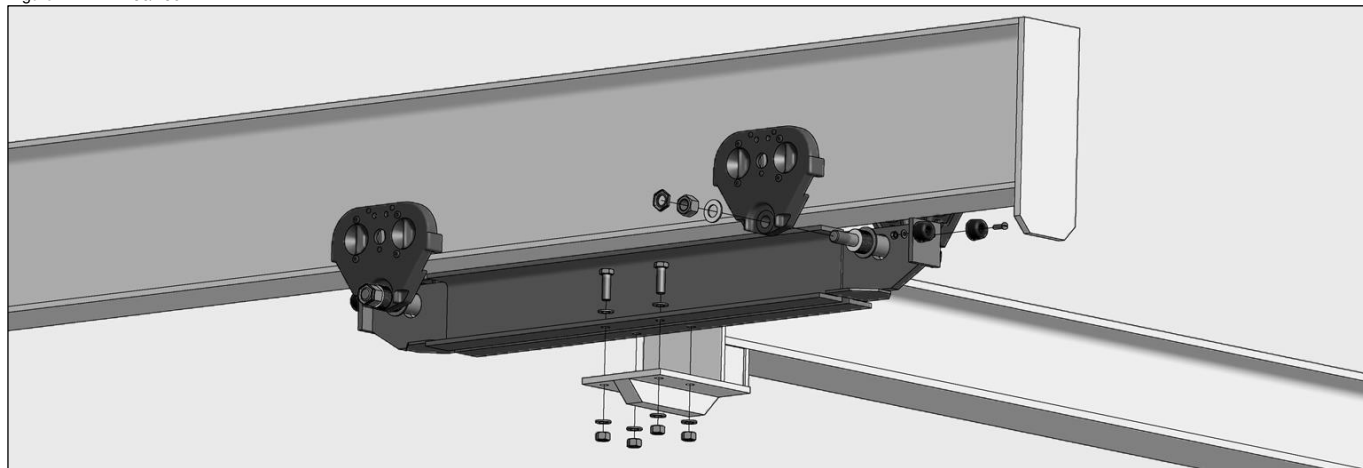
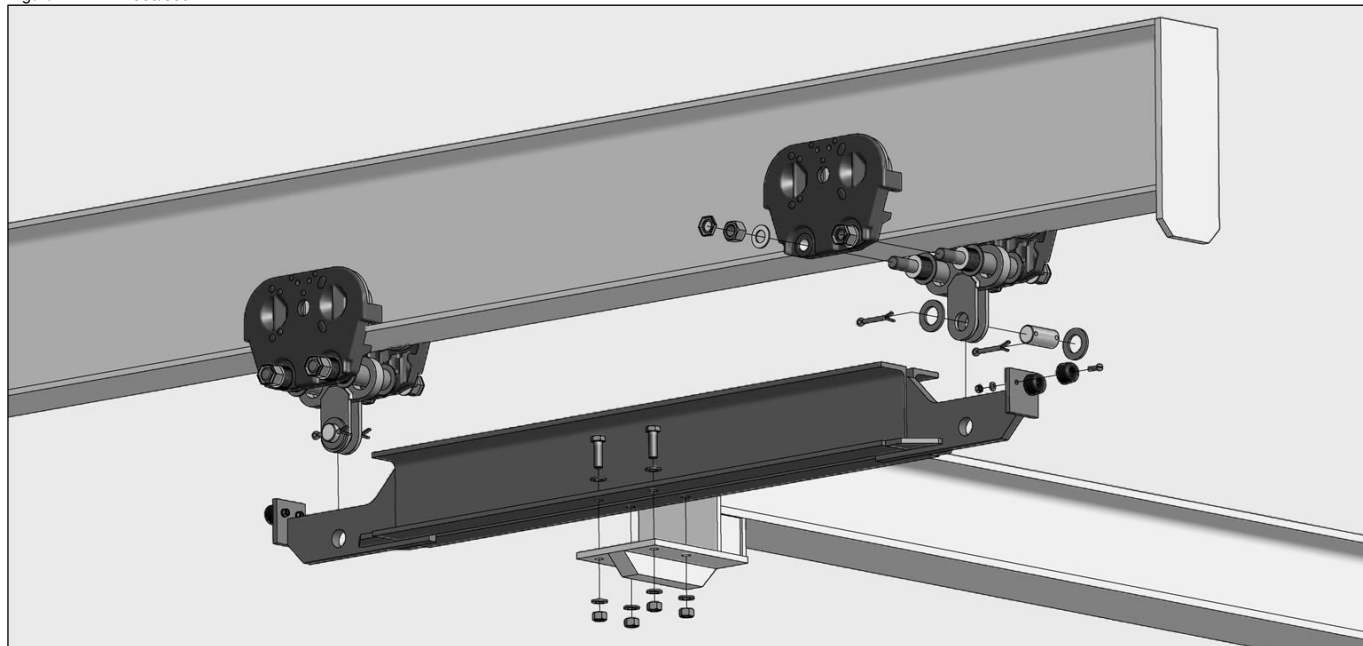

Figure 2-2 ERK 300/500



3 Appendix

3.1 EC Declaration of incorporation



EC DECLARATION OF INCORPORATION

Declaration for the incorporation of a partly completed machinery according to the EU directive 2006/42/EC, Annex II B

Hereby we,

GIS AG, Swiss Lifting Solutions, Luzernerstrasse 50, CH-6247 Schötz

declare that the partly completed machinery



**GIS crane components, series
with a load capacity**

**ERK
up to 5000 kg**

which is developed for transporting loads, which is designed for incorporation in machinery meets the essential requirements of the following EC directive, as applicable to the scope of delivery:

EC Machinery directive

2006/42/EC

We also declare that the technical documentation has been compiled in accordance with Annex VII, Part B of Directive 2006/42/EC. We undertake to submit the specific documents relating to the crane components to national authorities on receipt of a reasonable request. The information will be supplied by electronic means.

Harmonized standards applied:

DIN EN ISO 12100 General principles for design; Risk assessment and risk reduction

Standards and technical specifications applied:

DIN 15018-1 Cranes; basic principles for steel support structures; calculation
DIN 15019-1 Cranes; stability

Accident prevention regulations

This declaration only refers to the crane components. A start-up is prohibited until it is proven that the crane where the components are built in corresponds with the above mentioned EC directive.

Authorised to compile relevant technical documentation:

GIS AG, Luzernerstrasse 50, CH-6247 Schötz

Schötz, 20.02.2019

GIS AG

I. Muri
Director

E. Widmer
Sales Manager

Type	a	b	max. span width	c
ERK 50/ 800	1000	800	5000	- Dependent on size of cross beam - Recommendation to DIN 997
ERK 50/ 1200	1400	1200	7500	
ERK 50/ 1600	1800	1600	10000	
ERK 50/ 2000	2200	2000	12500	

- Lifting capacity max. 1000kg
- Drilling for crossbeam on site
- Colour: grey primed

Side with gap

Side without gap

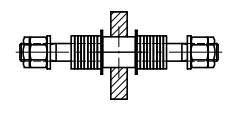

Spindle Nr.1
9247.1002.3

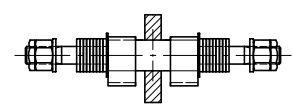
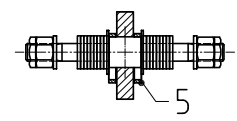

Spindle Nr.2
9247.1003.3

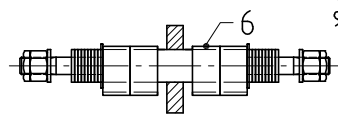
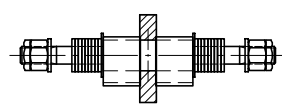

Spindle Nr.3
9247.1004.3

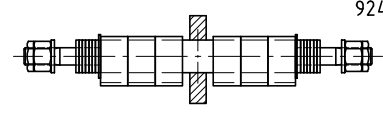
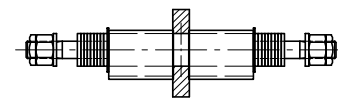

Spindle Nr.4
9247.1005.3

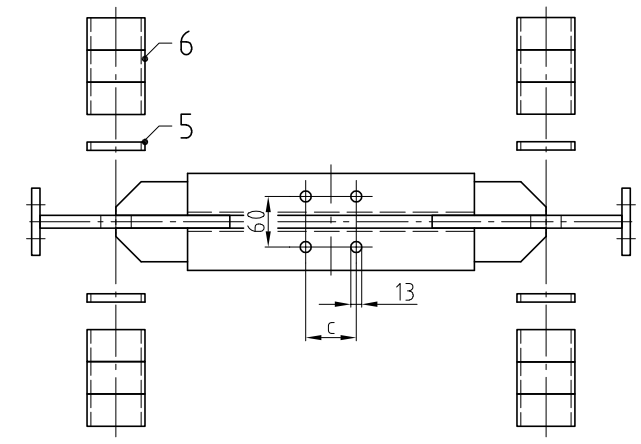
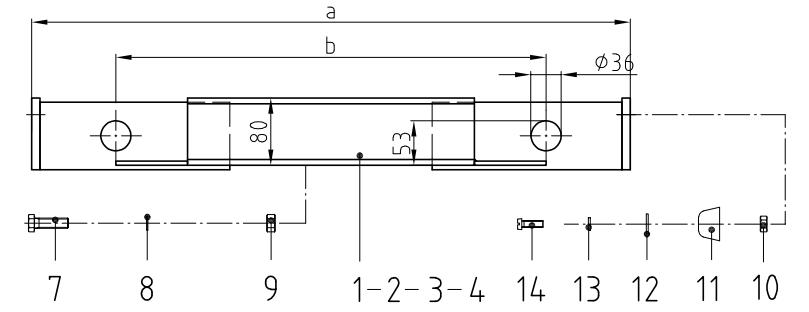
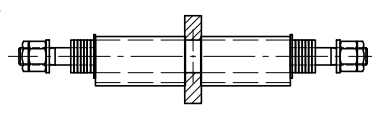

	Stückzahl Quantity			
	VI	III	II	I
ERK 50/ 2000	8	8	8	8
ERK 50/ 1600	8	8	8	8
ERK 50/ 1200	8	8	8	8
ERK 50/ 800	8	8	8	8

8	8	8	8	Slotted cheese head screw M8x25	St 4,8, vz	14	0030.3505
8	8	8	8	Spring washer M8	FSf, vz	13	9031.3904
8	8	8	8	Washer 8.4/17x1.6	St, vz	12	0031.0578
8	8	8	8	Buffer 40x25	SBR	11	9038.4500
8	8	8	8	Hexagon nut M8, 0.8d	St 8, vz	10	0031.0008
8	8	8	8	Hexagon nut M12, 0.8d	St 8, vz	9	0031.0040
8	8	8	8	Spring washer M12	FSf, vz	8	9031.3907
8	8	8	8	Hexagon screw M12x40	St 8,8, vz	7	9030.5296
12	12	12	12	Distance tube L=25	E235	6	9247.1007.4
4	4	4	4	Pipe R45/3x6.5	E235	5	9247.1506.4
2				Basic side frame l=2000	S235JR	4	9247.1504.3
	2			Basic side frame l=1600	S235JR	3	9247.1503.3
		2		Basic side frame l=1200	S235JR	2	9247.1502.3
			2	Basic side frame l=800	S235JR	1	9247.1501.3

Bezeichnung / Dimension			Werkstoff	Pos.	Artikel-Nr.
Freigegeben			Klasse:	Ersatz durch	Ersatz für
REV.	DATUM	USER	Basic side frame set		
A			Massstab 1:5		
Gezeichnet	J.SUPPIGER		ERK50 Technical datasheet		
			swiss lifting solutions		9248.9216.1
					Revision A

Type	a	b	max. span width	c
ERK 150/ 800	1000	800	5000	- dependent on size
ERK 150/ 1200	1400	1200	7500	- of cross beam
ERK 150/ 1600	1800	1600	10000	- Recommendation to DIN 997
ERK 150/ 2000	2200	2000	12500	

- Lifting capacity max. 2000kg
- Drilling for cross beam on site
- Colour: grey primed

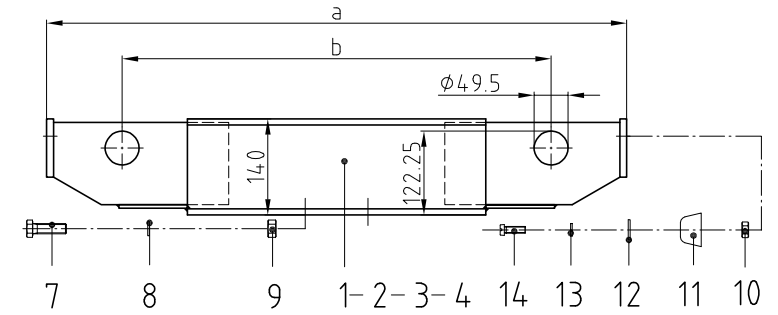

Side with gap

Side without gap

Spindle No.1
9248.1002.3

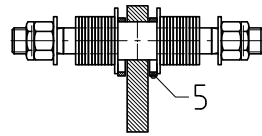
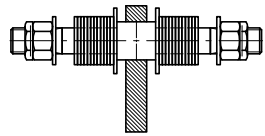

Spindle No.2
9248.1003.3

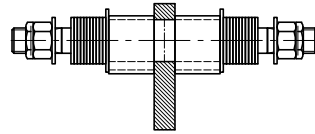
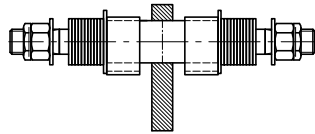

Spindle Nr.3
9248.1004.3

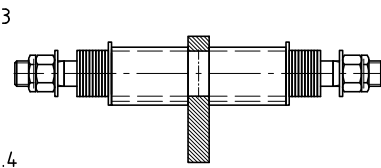
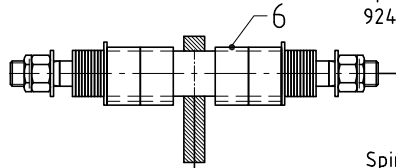

Spindle Nr.4
9248.1005.3

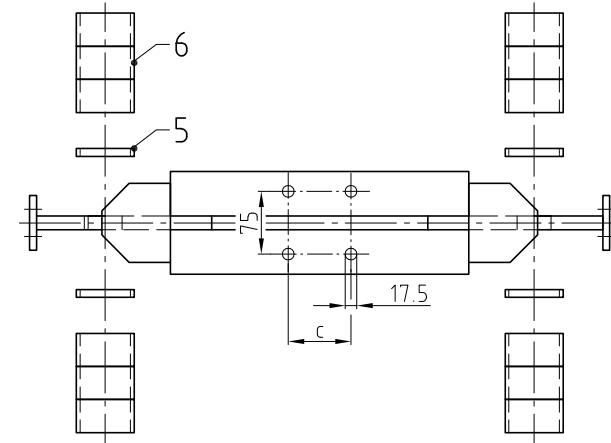
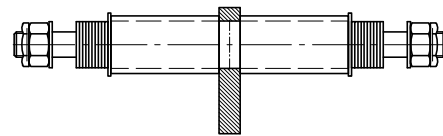
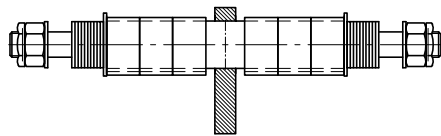

Stückzahl Quantity			
VI	III	II	I
ERK 150/ 2000	ERK 150/ 1600	ERK 150/ 1200	ERK 150/ 800

8	8	8	8	Slotted cheese head screw M8x25	St 4,8, vz	14	0030.3505
8	8	8	8	Spring washer M8	FSt, vz	13	9031.3904
8	8	8	8	Washer 8.4/17x1.6	St, vz	12	0031.0578
8	8	8	8	Buffer $\phi 40 \times 25$	SBR	11	9038.4500
8	8	8	8	Hexagon nut M8, 0.8d	St 8, vz	10	0031.0008
8	8	8	8	Hexagon nut M16, 0.8d	St 8, vz	9	0031.0042
8	8	8	8	Washer HV M16	St, vz	8	9031.3229
8	8	8	8	Hexagon screw M16x50	St 8,8, vz	7	9030.5304
12	12	12	12	Distance tube L=31.5	E235	6	9248.1009.4
4	4	4	4	Pipe R55/3.5x7.5	E235	5	9249.1501.4
2				Basic side frame l=2000	S235JR	4	9248.1504.3
	2			Basic side frame l=1600	S235JR	3	9248.1503.3
		2		Basic side frame l=1200	S235JR	2	9248.1502.3
			2	Basic side frame l=800	S235JR	1	9248.1501.3

Bezeichnung / Dimension			Werkstoff	Pos.	Artikel-Nr.
Norm freigeben			Klasse:	Ersetzt durch	Ersatz für
REV.	DATUM	USER	Basic side frame set		
A			Massstab 1:5		
Gezeichnet	J. SUPPGER		ERK150 Technical datasheet		
			swiss lifting solutions		9248.9221.1
					Revision A

Type	a	b	max. span width	c
ERK 300/ 800	1040	800	5000	- dependent on size of cross beam
ERK 300/ 1200	1440	1200	7500	- Recommendation to DIN 997
ERK 300/ 1600	1840	1600	10000	
ERK 300/ 2000	2240	2000	12500	

- Lifting capacity max. 4000kg
- Drilling for cross beam on site
- Colour: grey primed

Side with gap

Side without gap

Spindle Nr.1
9248.1002.3

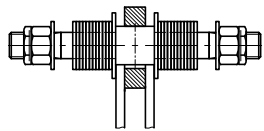

Spindle Nr.2
9248.1003.3

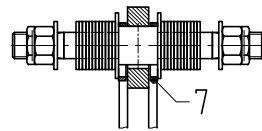

Spindle Nr.3
9248.1004.2

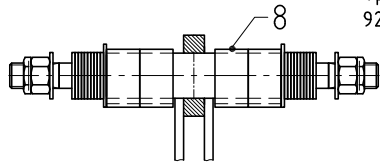

Spindle Nr.4
9248.1005.2

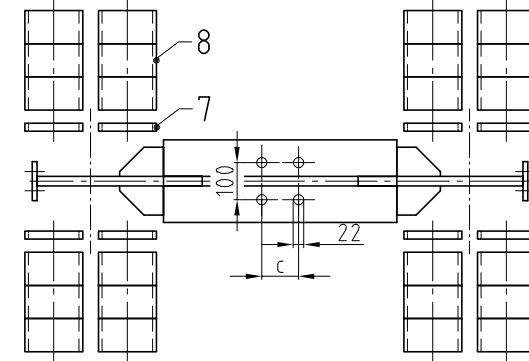
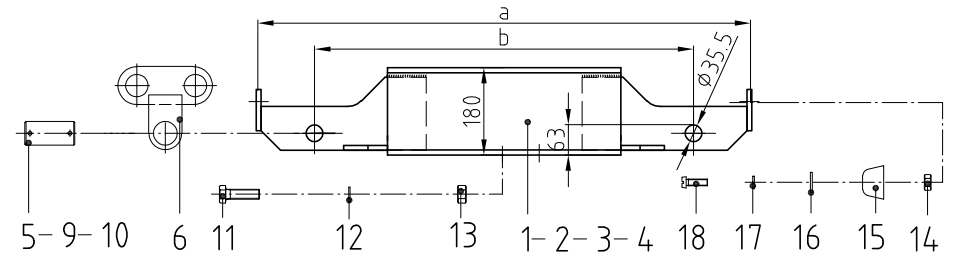
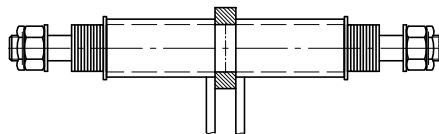
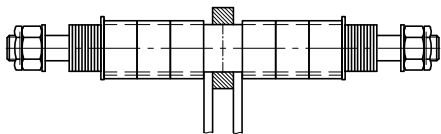

Stückzahl Quantity				VI	III	II	I		Werkstoff	Pos.	Artikel-Nr.
ERK 300/ 2000	ERK 300/ 1600	ERK 300/ 1200	ERK 300/ 800								
8	8	8	8	8	8	8	8	Slotted cheese head screw M8x25	St 4.8, vz	18	0030.3505
8	8	8	8	8	8	8	8	Spring washer M8	FSt, vz	17	9031.3904
8	8	8	8	8	8	8	8	Washer 8.4/17x1.6	St, vz	16	0031.0578
8	8	8	8	8	8	8	8	Buffer $\phi 40 \times 25$	SBR	15	9038.4500
8	8	8	8	8	8	8	8	Hexagon nut M8, 0.8d	St 8, vz	14	0031.0008
8	8	8	8	8	8	8	8	Hexagon nut M20, 0.8d	St 8, vz	13	0031.0043
8	8	8	8	8	8	8	8	Washer HV M20	FSt, vz	12	9031.3930
8	8	8	8	8	8	8	8	Hexagon screw M20x50	St 8.8, vz	11	9030.5305
8	8	8	8	8	8	8	8	Washer 60/36x5	St vz	10	9031.3009
8	8	8	8	8	8	8	8	Splint pin $\phi 8 \times 71$	St vz	9	0031.5080
24	24	24	24	24	24	24	24	Distance tube L=31.5	E235	8	9248.1009.4
8	8	8	8	8	8	8	8	Pipe R55/3.5x7.5	E235	7	9249.1501.4
4	4	4	4	4	4	4	4	Pivot unit	S235JR	6	9249.1500.3
4	4	4	4	4	4	4	4	Bolt	C35E	5	9249.1502.4
2								Basic side frame l=2000	S235JR	4	9244.3010.3
	2							Basic side frame l=1600	S235JR	3	9244.3009.3
		2						Basic side frame l=1200	S235JR	2	9244.3008.3
			2					Basic side frame l=800	S235JR	1	9244.3007.3

Bezeichnung / Dimension			Werkstoff	Pos.	Artikel-Nr.
Schnelle Änderung			Klasse:	Ersetzt durch	Ersetzt für
REV.	DATUM	USER	Basic side frame set		
A			ERK300 Technical datasheet		
Bezeichnet		J.SUPPIGER	Massstab	1:5	1 /



swiss lifting solutions

9248.9222.1

Revision

A

Type	a	b	max. span width	c	
ERK 300/500/ 800	1040	800	5000	- Dependent on size of cross beam	- Lifting capacity max. 5000kg - Drilling for cross beam on site - Colour: grey primed
ERK 300/500/ 1200	1440	1200	7500		
ERK 500/ 1600	1840	1600	10000	- Recommendation to DIN 997	
ERK 500/ 2000	2240	2000	12500		

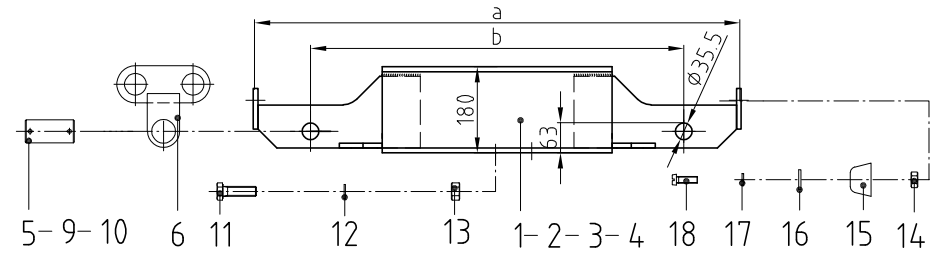

Side with gap

Side without gap

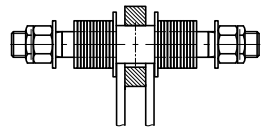

Spindle Nr.1
9248.1002.3

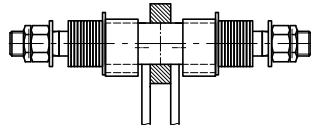
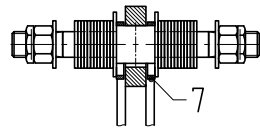

Spindle Nr.2
9248.1003.3

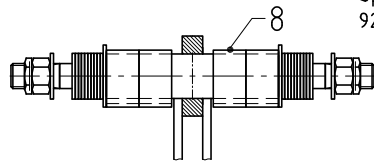
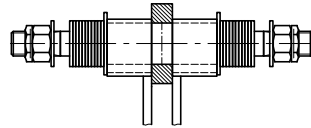

Spindle Nr.3
9248.1004.2

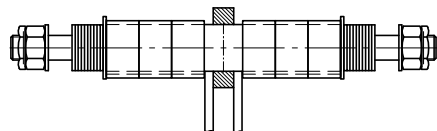
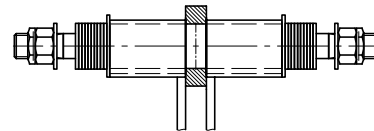

Spindle Nr.4
9248.1005.2

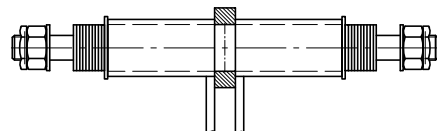

Stückzahl Quantity			
VI	III	II	I
ERK 500/ 2000	ERK 500/ 1600	ERK 300/ 500/ 1200	ERK 300/ 500/ 800

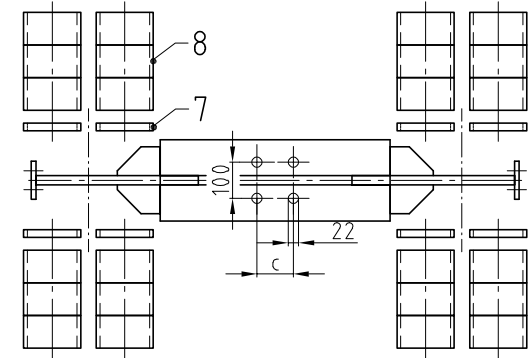

8	8	8	8	Slotted cheese head screw M8x25	St 4,8, vz	18	0030.3505
8	8	8	8	Spring washer M8	FSt, vz	17	9031.3904
8	8	8	8	Washer 8.4/17x1.6	St, vz	16	0031.0578
8	8	8	8	Buffer $\phi 4.0 \times 25$	SBR	15	9038.4500
8	8	8	8	Hexagon nut M8, 0.8d	St 8, vz	14	0031.0008
8	8	8	8	Hexagon nut M20, 0.8d	St 8, vz	13	0031.0043
8	8	8	8	Washer HV M20	FSt, vz	12	9031.3930
8	8	8	8	Hexagon screw M20x50	St 8,8, vz	11	9030.5305
8	8	8	8	Washer 60/36x5	St vz	10	9031.3009
8	8	8	8	Splint pin $\phi 8 \times 71$	St vz	9	0031.5080
24	24	24	24	Distance tube L=31.5	E235	8	9248.1009.4
8	8	8	8	Pipe R55/3.5x7.5	E235	7	9249.1501.4
4	4	4	4	Pivot unit	S235JR	6	9249.1500.3
4	4	4	4	Bolt	C35E	5	9249.1502.4
2				Basic side frame l=2000	S235JR	4	9249.1503.4
	2			Basic side frame l=1600	S235JR	3	9249.1504.3
		2		Basic side frame l=1200	S235JR	2	9244.3008.3
			2	Basic side frame l=800	S235JR	1	9244.3007.3

Bezeichnung / Dimension			Werkstoff	Pos.	Artikel-Nr.
Freigegeben			Klasse:	Ersetzt durch	Ersetzt für
REV.	DATUM	USER	Basic side frame set		
A			ERK500 Technical datasheet		
Gezeichnet		J SUPPIGER	Massstab	1:5	1/
			swiss lifting solutions		Revision
					A

9248.9237.1